

# Product Information Telescopic Wheel Loader

## L 509

Tele



### Generation

6

### Tipping Load

3,800 kg

### Max. Payload for Fork Carrier and Fork

2,300 kg<sup>1)</sup>

### Max. Lifting Height for Fork Carrier and Fork

4,800 mm

### Engine

Stage V

<sup>1)</sup> Recommended payload for smooth surfaces = 80 % of tipping load, articulated – according to 474-3

# LIEBHERR





**L 509 Tele**

**Tipping Load**

3,800 kg

**Bucket Capacity**

0.9 m<sup>3</sup>

**Operating Weight**

7,000 kg

**Max. Payload for Fork Carrier and Fork**

2,300 kg<sup>1)</sup>

**Max. Lifting Height for Fork Carrier and Fork**

4,800 mm

**Engine Output**

54 kW/73 HP

<sup>1)</sup> Recommended payload for smooth surfaces = 80 % of tipping load, articulated – according to 474-3

## **Performance**

The high-performance Liebherr telescopic wheel loader L 509 Tele is the ideal solution for all applications, especially for industrial use. The specially designed telescopic lift arm enables high manipulation heights and long reach. The L 509 Tele achieves a lifting height of up to 4.8 metres and is particularly suitable for loading trucks and containers as well as for lifting and stacking loading material. The powerful Z-bar linkage of the telescopic lift arm is specially adapted to the requirements of the telescopic wheel loader. The optimised linkage offers extremely precise parallel guidance in fork operation without manual readjustment. This ensures a simple and safe way of working when loading and stacking, even with heavy loads. The hydraulic quick hitch allows quick and efficient attachment changeover. This widens the machine's areas of use and therefore increases its productivity. The wide variety of options for specific requirements also increases the range of possible applications. The unique steering system and the compact design make the telescopic wheel loader extremely agile and versatile. This ensures maximum manoeuvrability and, at the same time, maximum stability in all site situations. This guarantees precise and safe work and improved efficiency.

## **Economy**

The compact design as well as the ideal weight distribution in combination with the unique stereo steering ensure safe transport of high payloads and thus an excellent handling capacity. The powerful hydrostatic Liebherr driveline allows continuous regulation of acceleration without noticeable gear shifting or interruption in tractive force. The L 509 Tele is available as Speeder as standard and reaches a top speed of 38 km/h. The machine is therefore ideally suited for all applications and long distances. The cooling is demand-controlled, which saves fuel and reduces maintenance costs. The cooling air is drawn into the system laterally behind the operator's cab and flows crossways through the entire engine compartment. This reduces cleaning expenses and at the same time improves the cooling performance. At maximum handling capacity and efficiency, this reduces operating costs significantly, further increasing profitability.

## **Reliability**

The use of ideally matched components and the stable machine design make the telescopic wheel loader extremely powerful and guarantee a long life. Reliable operations are possible in even the toughest conditions. The customer therefore has the machine power available when it is urgently required. The intelligent overload warning system consists of load torque limit and load torque indicator via display. These aids constantly inform the operator about the load situation and stability of the machine. Before the stability limit of the machine is reached in the forward tilting direction, the movements of the working hydraulics slow to a standstill. At the same time, when the maximum lifting load is exceeded, the operator is automatically alerted by visual warnings on the display and an acoustic signal. This means that the operator can work with safety and concentration, which significantly increases productivity.

## **Comfort**

The extremely comfortable cab allows the operator to concentrate on accurate operation without fatigue, which once again means more efficiency and productivity. Well laid out and ergonomically arranged controls guarantee simple handling. The Liebherr control lever with mini-joystick, which is built into the operator's seat as standard, allows precise and sensitive control of the machine. The generous glass surfaces as well as the roof glass panel of the cab and the specially designed telescopic linkage offer exceptional all-round visibility for all lift arm positions. Moreover, the design of the engine hood which has been optimised for viewing as well as the optional rear area monitoring camera ensure ideal visibility. The oscillating centre pivot compensates for unevenness on the ground and provides excellent stability and maximum ride comfort. Even in constricted spaces, maximum safety for people, the machine and the load is guaranteed, while at the same time increasing productivity. Efficient and convenient operation of the machine is ensured with the option package "Tele comfort operation" – with automatic, programmable bucket return-to-dig, programmable, automatic lifting and lowering as well as visualisation of the equipment position.

## **Maintainability**

The most important points for daily maintenance can be reached safely and conveniently from the ground. The entire engine compartment is accessible via just one enclosure. Quick and safe checks save time and money.



# Safety in and Around the Machine

## Cargo Safety

- + Robust, durable telescopic lift arm
- + High loads with maximum reach and lifting height
- + Safe lifting of the load without manual adjustment and without loss of load
- + Fast and safe positioning of the load
- ✓ Strong steel construction
- ✓ Telescopic lift arm with powerful Z-bar linkage
- ✓ Optimised parallel guidance during fork operation over the entire lifting range
- ✓ Intelligent overload warning system

## Personnel Safety

- + Excellent all-round visibility
- + Optimal visibility of the equipment and the load
- ✓ Generous glass surfaces and roof glass panel of the operator's cab
- ✓ Optimised visibility thanks to optimal cab and engine hood design
- ✓ Hydraulic quick hitch

## Stability and Tipping Safety

- + Maximum stability and safety on all terrains
- + Maximum manoeuvrability
- + Comfortable and stable driving performance
- + Maximum productivity by high payload
- ✓ Stereo steering with just 30° angle of articulation
- ✓ Unique oscillating centre pivot
- ✓ Intelligent overload warning system
- ✓ Excellent ratio between operating weight and tipping load





### **Operating Safety**

- + Increased performance and productivity
- + Focused operator work is supported
- + Simple handling, can be learned quickly
- + Efficient and simple checks to ensure the machine is safe to use
- ✓ New, modern and ergonomic cab design
- ✓ Control of working and travel functions with one control lever
- ✓ Ergonomic and intuitive arrangement of control instruments
- ✓ All maintenance and check points are easily accessible by walking around the machine

### **Safe and Versatile Usage**

- + Performance-oriented and cost-optimised use
- + Efficient and flexible use, even in confined spaces
- + Flexible in use
- + High performance
- + Constant and reliable cooling
- + High machine availability through minimal cleaning expenses
- + Time savings in daily maintenance
- ✓ Most efficient hydrostatic driveline, Speeder (38 km/h)
- ✓ Extreme agility thanks to stereo steering and oscillating centre pivot
- ✓ Wide range of attachments
- ✓ Stable machine design and robust components optimally suited to each other
- ✓ Controlled transverse cooling
- ✓ The radiator is installed laterally behind the operator's cab
- ✓ Rapid control of all maintenance points from the ground

# Technical Data



## Engine

<b>Diesel engine</b>	4TNV98CT
Design	Water-cooled turbocharged in-series diesel engine
Cylinder inline	4
Fuel injection process	Electronic Common Rail high-pressure injection
Output to ISO 9249 ~ SAE J1349	kW/HP 52/71 at RPM 2,400
Rated output to ISO 14396/ ECE-R.120	kW/HP 54/73
Nominal speed	at RPM 2,400
Max. torque to ISO 14396	Nm 280 at RPM 1,800
Displacement	litres 3.32
Bore/Stroke	mm 98/110
<b>Stage V</b>	
Harmful emissions values	According to regulation (EU) 2016/1628
Emission control	Closed diesel particle filter system
Fuel tank	litres 90
<b>Air cleaner system</b>	Dry type filter with main and safety element
<b>Electrical system</b>	
Operating voltage	V 12
Capacity	Ah 100
Alternator	V/A 12/80
Starter	V/kW 12/3



## Driveline

<b>Hydrostatic driveline – Speeder</b>	
Design	2-speed automated gearbox, swash plate type variable flow pump and variable axial piston motor in closed loop circuit
Filtration	Suction return line filter for closed circuit
Control	By travel and inching pedal. The inching pedal makes it possible to control the tractive and thrust forces steplessly at full engine speed. The Liebherr control lever is used to control forward and reverse travel
<b>Travel speed range</b>	Speed range 1 _____ 0 – 18 km/h Speed range 2 _____ 0 – 38 km/h forward and reverse Speeds quoted apply with the tyres indicated as standard on loader model.

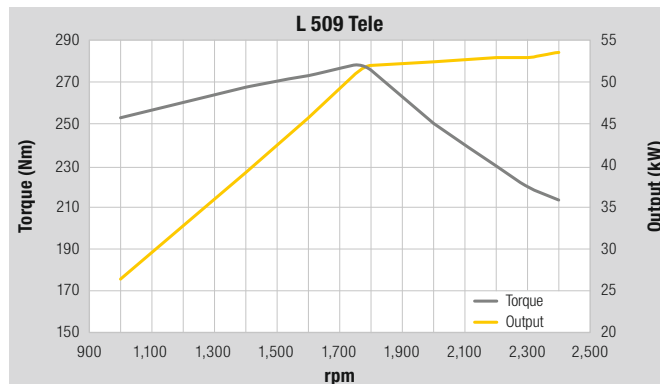

## Axles

<b>Four-wheel drive</b>	
<b>Front axle</b>	Fixed
<b>Rear axle</b>	Axle pivot steering, fixed
Height of obstacles which can be driven over	mm 370 with all four wheels remaining in contact with the ground
<b>Differentials</b>	100% differential lock in front axle, manually engaged
<b>Reduction gear</b>	Planetary final drive in wheel hubs
<b>Track width</b>	1,630 mm with tyres indicated as standard



## Brakes

<b>Service brake</b>	Wear-free service brake due to hydrostatic driveline, applied to all four wheels and additional dual-circuit brake system, drum brake and wet multi-disc brake located in the front axle
<b>Parking brake</b>	Negative brake system in the front axle acting on the wet multi-disc brakes

The braking system meets the requirements of the ISO 3450.



## Steering

<b>Design</b>	Stereo steering system, hydraulic servo power steering. Central oscillating frame articulation with damper element in combination with rear-axle pivot steering
<b>Angle of articulation</b>	30° to each side
<b>Angle of oscillation – centre-pivot steering</b>	8° to each side
<b>Max. pressure</b>	bar 180



## Attachment Hydraulics

<b>Design</b>	Gear pump to supply the hydraulic and steering systems (via priority valve)
<b>Cooling</b>	Hydraulic oil cooling using thermostatically controlled fan
<b>Filtration Control</b>	Suction return line filter in the hydraulic reservoir Liebherr control lever, electro-proportionally operated, 1st and 2nd additional hydraulic function electro-proportionally controlled optional
<b>Lifting function</b>	Lifting, neutral, lowering Float position controlled by Liebherr control lever with detent, automatic lift arm position and lowering by Liebherr control lever optional
<b>Tilt function</b>	Tilt back, neutral, dump Automatic bucket return for tilting back and dumping controlled by Liebherr control lever optional
<b>Telescope</b>	Telescoping extension and retraction controlled electro-proportionally operated by mini-joystick, stroke limit damping
<b>Max. flow</b>	l/min. 93
<b>Max. pressure</b>	bar 230



## Attachment

<b>Geometry</b>	Telescopic lift arm with powerful Z-bar linkage, hydraulic quick hitch as standard
<b>Cycle time at nominal load</b>	TK
Lifting	s 5.2
Dumping	s 2.0
Lowering (empty)	s 4.0
Extend	s 4.0
Retract	s 3.0



## Operator's Cab

<b>Design</b>	Elastic mounted, noise-proof cab ROPS roll over protection per EN ISO 3471 / EN 474-1 FOPS falling objects protection per EN ISO 3449 / EN 474-1, Cat. II Operator's door with 180° opening angle with rigid window, fold-out window on right with 12° gap opener or 180° opening, roof glass panel, roof glass panel windscreen wiper optional, single-pane safety glass ESG, heated rear window ESG, all windows are tinted. Continuously adjustable steering column optional
<b>Liebherr operator's seat</b>	5 way adjustable, vibration-damped operator's seat "Standard" (mechanically sprung, adjustable to operator's weight), Liebherr control lever mounted into the operator's seat as standard
<b>Cab heating and ventilation</b>	Fresh/recirculated air mode, cab heating via cooling water, arrangement of the air nozzles ensures quick defrosting and defogging of the windows, electrically heated rear window



## Sound Level

<b>Sound pressure level to ISO 6396</b>	
L <sub>pA</sub> (inside cab)	dB(A) 73
<b>Sound power level to 2000/14/EC</b>	
L <sub>WA</sub> (surround noise)	dB(A) 101



## Capacities

<b>Engine oil (inclusive filter change)</b>	l 10.2
<b>Travel gear/rear axle</b>	l 1.3
<b>Coolant</b>	l 9
<b>Front axle/differential</b>	l 6.8
<b>Rear axle/differential</b>	l 6
<b>Front axle/wheel hubs</b>	l 1.4
<b>Rear axle/wheel hubs</b>	l 1.4
<b>Hydraulic tank</b>	l 65
<b>Hydraulic system, total</b>	l 110



# Dimensions

## Telescopic linkage

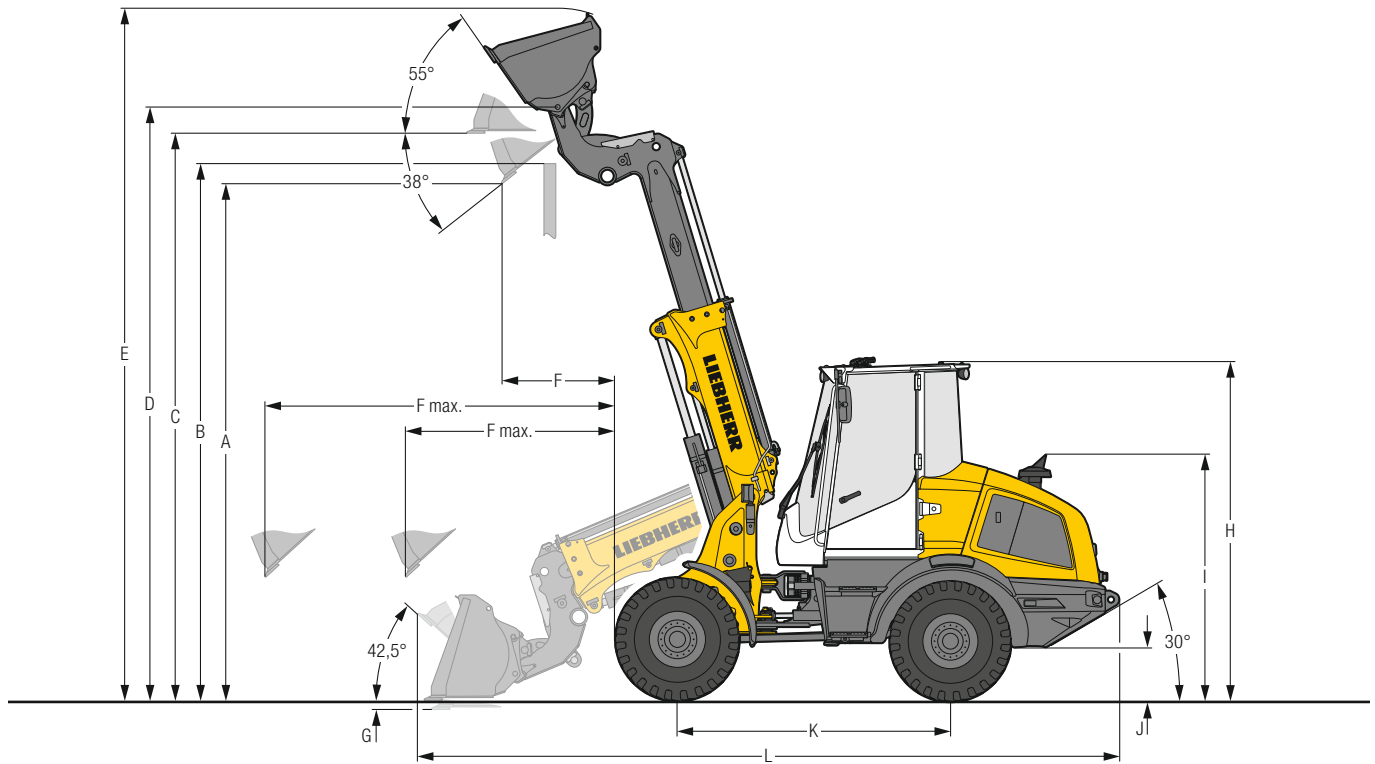

### Excavation Bucket



<b>Geometry</b>		TK-QH
<b>Cutting tools</b>		BOCE
<b>Lift arm length</b>	mm	2,475 / 3,650
<b>Bucket capacity according to ISO 7546**</b>	m <sup>3</sup>	0.9
<b>Specific material density</b>	t/m <sup>3</sup>	1.8
<b>Bucket width</b>	mm	2,200
<b>A Dumping height at max. lift height and 40° discharge</b>	mm	4,320
<b>B Dump-over height</b>	mm	4,500
<b>C Max. height of bucket bottom</b>	mm	4,760
<b>D Max. height of bucket pivot point</b>	mm	4,960
<b>E Max. operating height</b>	mm	5,790
<b>F Reach at max. lift height and 40° discharge</b>	mm	950
<b>F max. Max. reach at 42° discharge</b>	mm	1,750 / 2,930
<b>G Digging depth</b>	mm	90
<b>H Height above operator's cab<sup>1)</sup></b>	mm	2,790
<b>I Height above exhaust</b>	mm	2,020
<b>J Ground clearance</b>	mm	305
<b>K Wheelbase</b>	mm	2,300
<b>L Overall length</b>	mm	5,835
<b>Turning circle radius over outside bucket edge</b>	mm	4,225
<b>Breakout force (SAE)</b>	kN	49
<b>Tipping load, straight*</b>	kg	4,300
<b>Tipping load, fully articulated*</b>	kg	3,800
<b>Operating weight*</b>	kg	7,000
<b>Tyre size</b>		400/70R20 L3

\* The figures shown include the above tyres, all lubricants, a full fuel tank, the ROPS/FOPS cab and the operator. Different tyres and optional equipment will change the operating weight and tipping load. (Tipping load, fully articulated according to ISO 14397-1)

\*\* Actual bucket capacity may be approx. 10% larger than the calculation according to ISO 7546 standard. The degree to which the bucket can be filled depends on the material – see page 11.

<sup>1)</sup> Available option of "roof glass panel windscreen wiper" the value "H" increases to 50 mm.

TK-QH = Telescopic linkage incl. quick hitch  
BOCE = Bolt-on cutting edge



# Attachment

## Light Material Bucket

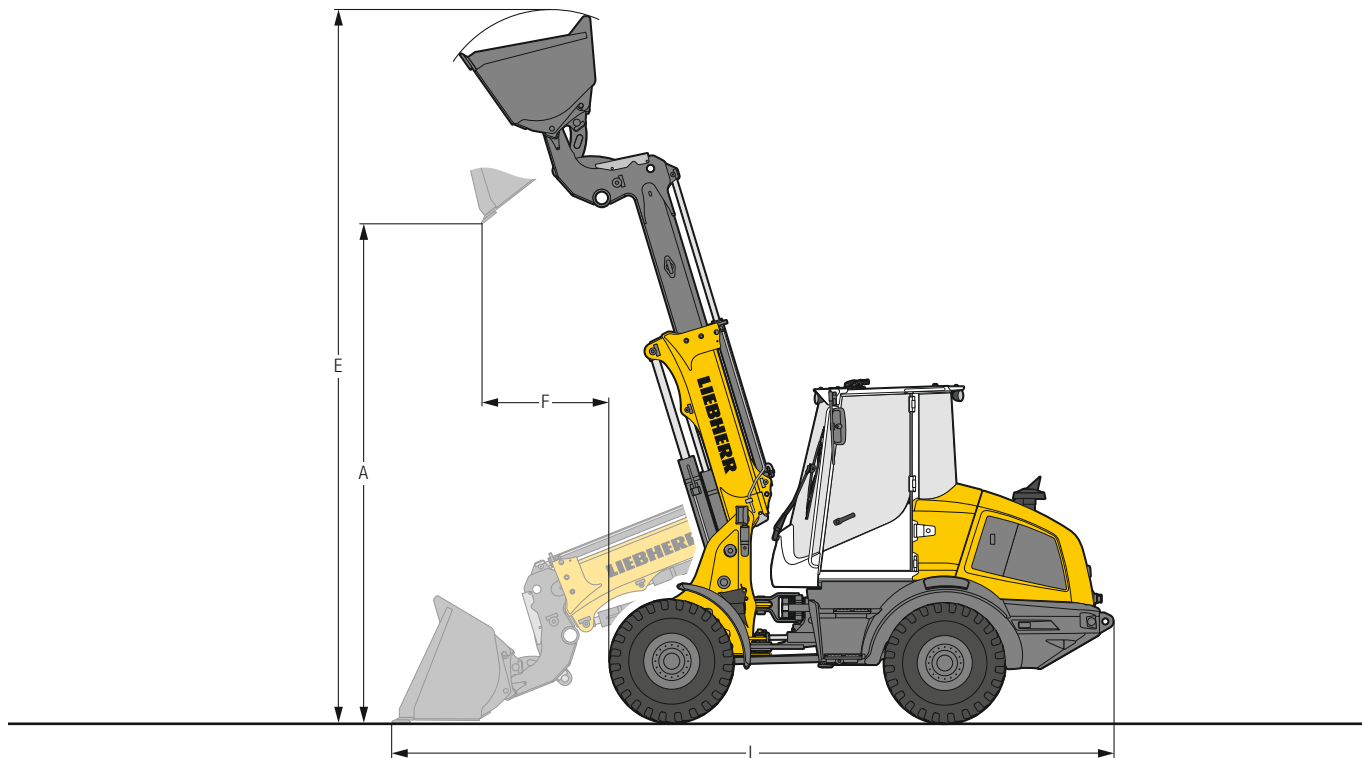

### Heavy Material Density

Geometry		TK-QH	TK-QH
Cutting tools		BOCE	BOCE
Bucket capacity	m <sup>3</sup>	1.6	2.0
Specific material density	t/m <sup>3</sup>	1.0	0.8
Bucket width	mm	2,400	2,400
<b>A</b> Dumping height at max. lift height	mm	4,165	4,085
<b>E</b> Max. operating height	mm	5,790	5,950
<b>F</b> Reach at maximum lift height	mm	1,055	1,170
<b>L</b> Overall length	mm	6,050	6,195
Tipping load, straight*	kg	4,100	4,050
Tipping load, fully articulated*	kg	3,650	3,600
Operating weight*	kg	7,100	7,150
Tyre size		400/70R20 L3	

\* The figures shown include the above tyres, all lubricants, a full fuel tank, the ROPS/FOPS cab and the operator. Different tyres and optional equipment will change the operating weight and tipping load. (Tipping load, fully articulated according to ISO 14397-1)

TK-QH = Telescopic linkage incl. quick hitch

BOCE = Bolt-on cutting edge

# Attachment

## Fork Carrier and Fork

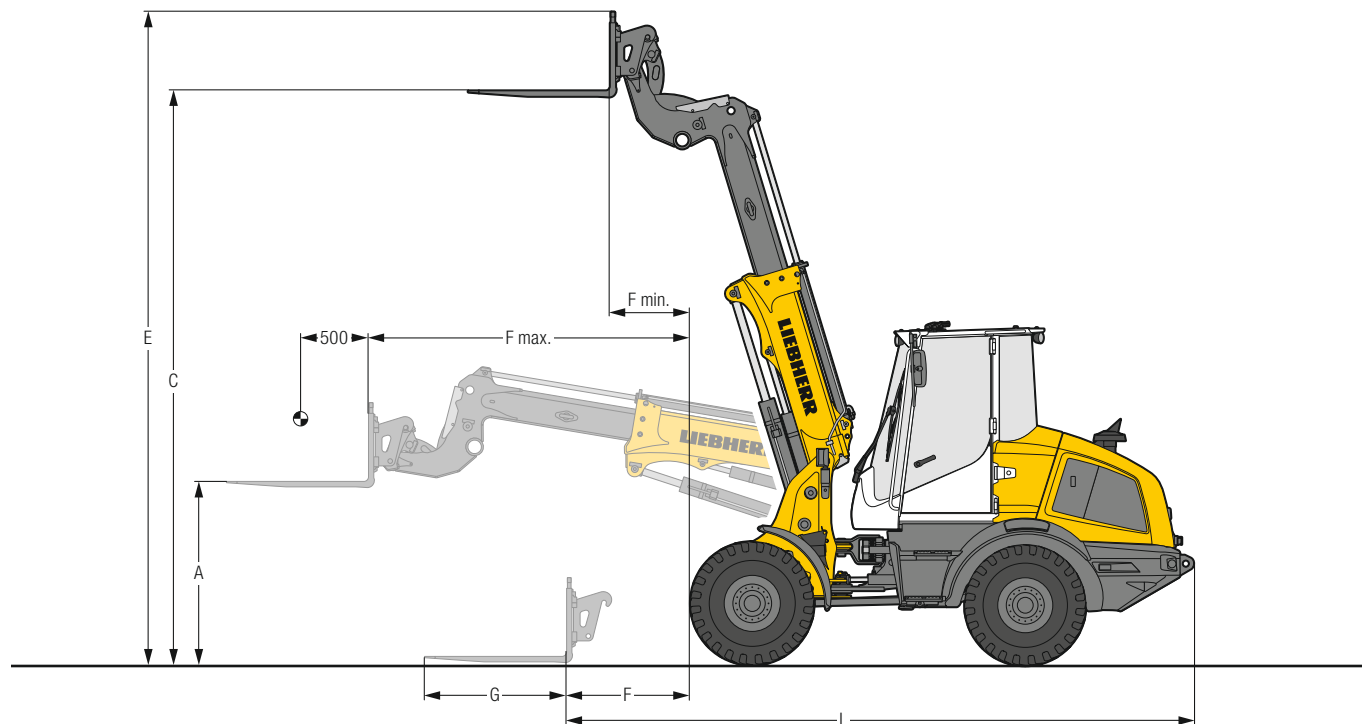

### FEM II Fork Carrier and Fork



Geometry			TK-QH
A	Lifting height at max. reach	mm	1,530
C	Max. lifting height	mm	4,800
E	Max. operating height	mm	5,460
F	Reach at loading position	mm	1,030
F max.	Max. reach	mm	1,515/2,695
F min.	Reach at max. lifting height	mm	660
G	Fork length	mm	1,200
L	Length – basic machine	mm	5,270
	Tipping load, straight*	kg	3,400
	Tipping load, fully articulated*	kg	3,050
	Recommended payload for uneven ground = 60% of tipping load, articulated <sup>1)</sup>	kg	1,800
	Recommended payload for smooth surfaces = 80% of tipping load, articulated <sup>1)</sup>	kg	2,300
	Operating weight*	kg	6,800
	Tyre size		400/70R20 L3

\* The figures shown include the above tyres, all lubricants, a full fuel tank, the ROPS/FOPS cab and the operator. Different tyres and optional equipment will change the operating weight and tipping load. (Tipping load, fully articulated according to ISO 14397-1)

<sup>1)</sup> According to EN 474-3

TK-QH = Telescopic linkage incl. quick hitch

# Bucket Selection

## L 509 Tele

Lift arm	Bucket	Material density (t/m <sup>3</sup> )	Material density (t/m <sup>3</sup> )										
			0.4	0.6	0.8	1.0	1.2	1.4	1.6	1.8	2.0		
TK-QH	GPB	0.9 m <sup>3</sup>										1.0	0.9
	LMB	1.6 m <sup>3</sup>				1.8	1.6						
		2.0 m <sup>3</sup>		2.2	2.0								

## Bucket Filling Factor

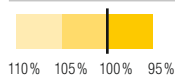

## Lift Arm

TK-QH	Telescopic linkage with quick hitch
-------	-------------------------------------

## Bucket

GPB	General purpose bucket (Excavation bucket)
LMB	Light material bucket

## Bulk Material Densities and Bucket Filling Factors

		t/m <sup>3</sup>	%			t/m <sup>3</sup>	%			t/m <sup>3</sup>	%
<b>Gravel</b>	moist	1.9	105	<b>Earth</b>	dry	1.3	115	<b>Glass waste</b>	broken	1.4	100
	dry	1.6	105		wet excavated	1.6	110		solid	1.0	100
	crushed stone	1.5	100	<b>Topsoil</b>		1.1	110	<b>Compost</b>	dry	0.8	105
<b>Sand</b>	dry	1.5	105	<b>Basalt</b>		1.95	100	wet	1.0	110	
	wet	1.9	110	<b>Granite</b>		1.8	95	<b>Wood chips/Saw dust</b>		0.5	110
<b>Gravel and Sand</b>	dry	1.7	105	<b>Sandstone</b>		1.6	100	<b>Paper</b>	shredded/loose	0.6	110
	wet	2.0	100	<b>Slate</b>		1.75	100	recovered paper/cardboard	1.0	110	
<b>Sand/Clay</b>		1.6	110	<b>Bauxite</b>		1.4	100	<b>Coal</b>	heavy material density	1.2	110
<b>Clay</b>	natural	1.6	110	<b>Limestone</b>		1.6	100	light material density	0.9	110	
	dry	1.4	110	<b>Gypsum</b>	broken	1.8	100	<b>Waste</b>	domestic waste	0.5	100
<b>Clay/Gravel</b>	dry	1.4	110	<b>Coke</b>		0.5	110	bulky waste	1.0	100	
	wet	1.6	100	<b>Slag</b>	broken	1.8	100				

# Load Curve

## L 509 Tele FEM II Fork Carrier and Fork

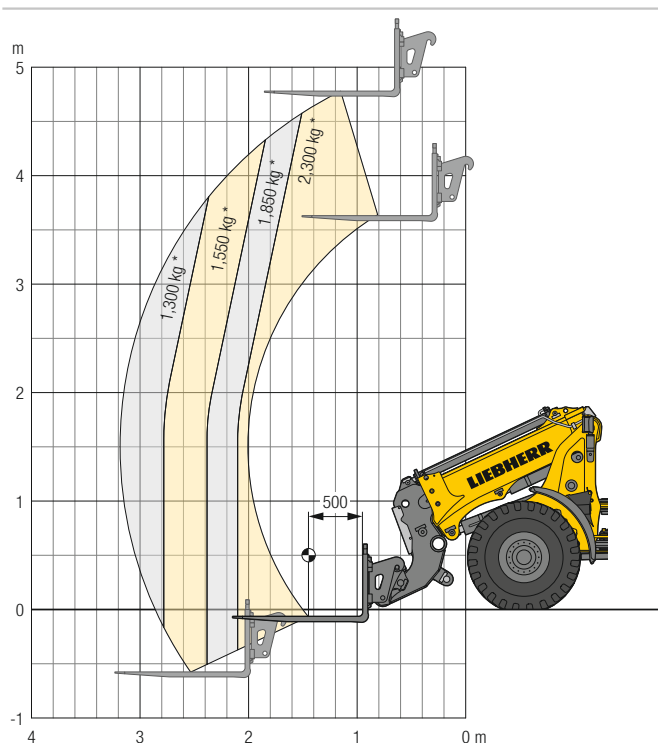

\* Recommended payload for smooth surfaces = 80% of tipping load, articulated – according to 474-3



# Tyres



## Tyre Types

	Size and tread code		Change of operating weight kg	Width over tyres mm	Change in vertical dimensions* mm	Use
<b>L 509 Tele Speeder</b>						
Dunlop	365/80R20 SP T9	L2	4	2,040	31	Sand, Gravel, Asphalt (all ground conditions)
Dunlop	405/70R18 SP T9	L2	- 16	2,080	- 1	Sand, Gravel, Asphalt (all ground conditions)
Dunlop	405/70R20 SP T9 <sup>1)</sup>	L2	40	2,080	25	Sand, Gravel, Asphalt (all ground conditions)
Dunlop	15.5/55R18 SP PG7	L2	- 88	2,050	- 53	Sand, Gravel, Asphalt (all ground conditions)
Firestone	365/80R20 Duraforce UT	L3	24	2,050	28	Gravel, Asphalt, Industry (all ground conditions)
Firestone	400/70R20 Duraforce UT <sup>1)</sup>	L3	66	2,080	18	Gravel, Asphalt, Industry (all ground conditions)
Firestone	405/70R18 Duraforce UT	L3	36	2,090	- 2	Gravel, Asphalt, Industry (all ground conditions)
Firestone	400/70R20 R8000 UT <sup>1)</sup>	L2	43	2,080	18	Earthworks, Green area (all ground conditions)
Michelin	9.00R20 X MINE D2	L5	268	2,030	22	Stone, Scrap, Recycling (firm ground conditions)
Michelin	400/70R20 BIBLOAD <sup>1)</sup>	L3	40	2,080	13	Gravel, Asphalt, Industry (firm ground conditions)
Michelin	400/70R20 XMCL <sup>1)</sup>	L2	56	2,090	19	Earthworks, Green area (all ground conditions)
Mitas	405/70R18 EM-01	L2	0	2,090	0	Gravel, Asphalt, Industry (all ground conditions)
Mitas	365/80R20 EM-01	L2	16	2,050	27	Gravel, Asphalt, Industry (all ground conditions)
Mitas	405/70R20 EM-01 <sup>1)</sup>	L2	36	2,090	25	Gravel, Asphalt, Industry (all ground conditions)
Trelleborg	400/70R20 TH400 <sup>1)</sup>	L2	50	2,080	13	Earthworks, Green area (all ground conditions)

\* The stated values are theoretical and may deviate in practice.

<sup>1)</sup> Recommended tyre sizes from Liebherr-Werk Bischofshofen GmbH for optimum lateral stability.

Before operating the vehicle with tyre foam filling or tyre protection chains, please discuss this with the Liebherr-Werk Bischofshofen GmbH.

# The Liebherr Telescopic Wheel Loaders

## Telescopic Wheel Loader



		L 509 Tele
Tipping load	kg	3,800
Bucket capacity	m <sup>3</sup>	0.9
Operating weight	kg	7,000
Max. payload for fork carrier and fork	kg	2,300 <sup>2)</sup>
Max. lifting height for fork carrier and fork	mm	4,800
Engine output	kW / HP	54 / 73

<sup>2)</sup> Recommended payload for smooth surfaces = 80 % of tipping load, articulated – according to 474-3

11.20

# Equipment



## Basic Wheel Loader

Connection for electrical equipment 7-pole	+
Automatic central lubrication system	+
Battery main switch (lockable)	•
Tool kit	•
Diesel particle filter	•
Ride control	+
Parking brake	•
Speed limitation 20 km/h or 30 km/h as a factory preset	+
Speed limitation adjustable on key	+
Pre-heat system for cold starting	•
Rear license panel light	+
Combined inching-braking system	•
Fuel pre-filter	•
Cooling water pre-heating 220 V	+
Liebherr biodegradable hydraulic oil	+
Reversible fan drive	+
Guard for headlights	+
Special paint	+
Speeder version	•
Auxiliary heater (Additional heating with engine preheating)	+
Power socket rear (13-pole, 12 V)	+
Lockable doors and engine hood	•
Load lashing lugs	•
Air pre-cleaner	+
Towing hitch	•



## Equipment

Working hydraulics lockout	•
Automatic bucket return programmable	+
Stroke limit damping	+
Fork carrier and pallet forks	+
High-Flow hydraulic	+
Automatic lift arm position and lowering programmable	+
Hydraulic connections rear	+
Hydraulic quick hitch	•
Loading buckets incl. a range of cutting tools	+
Light material bucket	+
Load holding valves telescopic cylinder	•
Headlights LED on the lift arm	+
Float position	•
Control lever lock	+
Telescopic linkage	•
Visualisation of the equipment position	+
1st electro-hydraulic, proportional additional function	•
1st and 2nd electro-hydraulic, proportional additional function	+

# Equipment



## Operator's Cab

Storage compartment	•
Storage box	•
Exterior mirror, tiltable	•
Exterior mirror, tiltable and heatable	+
Fold-out window right 180°	•
Operating hour meter (integrated in display unit)	•
Roof glass panel	•
Electronical theft protection with code	+
Operator seat "Comfort" – air sprung with seat heating	+
Operator seat "Standard" – mechanically sprung	•
Particle filter F5	•
Fire extinguisher in cab 2 kg	+
Cup holder	•
Inching device hand operated	+
Rear window heated electrically	•
Floor mat	•
Clothes hook	•
Air conditioning system	+
3 way continuously adjustable steering column (height-adjustable, tilting, folding)	+
Steering column folding	+
Steering column fixed	•
LiDAT (Liebherr data transfer system)	+
Liebherr control lever with mini-joystick for 1st hydraulic, proportional additional function moving with operator's seat (incl. travel direction)	•
Liebherr control lever with mini-joystick for 1st and 2nd hydraulic, proportional additional function moving with operator's seat (incl. travel direction)	+
Emergency exit	•
Premiumdisplay (Touchscreen), with height adjustment and tilting function	•
Preparation for radio installation	+
Radio Liebherr "Comfort" (USB/AUX/BLUETOOTH/handsfree set)	+
Radio Liebherr "Standard" (USB/AUX)	+

• = Standard  
+ = Option  
– = not available



## Operator's Cab

Interior rear-view mirror	•
Amber beacon LED	+
Soundproof ROPS/FOPS cab	•
Wipe system front/rear	•
Roof glass panel windscreen wiper	+
Headlights rear, single design, halogen/LED	+
Headlights rear, double design, LED	+
Headlights front, single design, halogen	•
Headlights front, single design, LED	+
Headlights front, double design, LED	+
Sliding window left	+
Sunblind rear	+
Sunblind for roof screen	+
Sunblind front	•
Power socket 12 V	•
First aid kit	+
Hot-water heater with defroster and recirculated air mode	•
Wide angle mirror	+



## Safety

Country-specific versions	+
Back-up alarm acoustical/visual	+
Rear space monitoring with camera (integrated in display unit)	+
Overload warning system with load torque limit and load torque indicator via display	•



Here you can download our wheel loader brochures: