

# Crawler Loaders

## LR 626

Litronic®

## LR 636

Litronic®



### Operating Weight

16,130 – 18,600 kg / 35,561 – 41,006 lb

21,100 – 22,700 kg / 46,510 – 50,040 lb

### Engine Output

SAE J1349

105 kW / 141 HP

135 kW / 181 HP

Stage IV / Tier 4f

ISO 9249

105 kW / 143 HP

135 kW / 184 HP

# LIEBHERR

## Performance

Outstanding Handling Capacity  
and Quick Work Cycles

## Efficiency

Cost Efficiency Comes Standard

### LR 626 Litronic

#### Engine (ISO 9249)

105 kW / 143 HP  
Tier 4f / EU Stage IV

#### Engine (SAE J1349)

105 kW / 141 HP  
Tier 4f / EU Stage IV

#### Operating Weight

16,130 – 18,600 kg  
35,561 – 41,006 lb

#### Bucket Capacity

1.50 – 1.80 m<sup>3</sup>  
1.96 – 2.35 yd<sup>3</sup>

#### Hydrostatic Travel Drive

with electronic control unit

### LR 636 Litronic

#### Engine (ISO 9249)

135 kW / 184 HP  
Tier 4f / EU Stage IV

#### Engine (SAE J1349)

135 kW / 181 HP  
Tier 4f / EU Stage IV

#### Operating Weight

21,100 – 22,700 kg  
46,510 – 50,040 lb

#### Bucket Capacity

1.90 – 4.60 m<sup>3</sup>  
1.96 – 2.35 yd<sup>3</sup>

#### Hydrostatic Travel Drive

with electronic control unit



## Reliability

Robust Design in Every Regard

## Comfort

Ample Space, Ergonomics and Comfort – All in One

## Maintainability

Simple Maintenance and an Extensive Service Network



# Performance



## Outstanding Handling Capacity and Quick Work Cycles

Power, agility and innovation are the hallmarks of Liebherr crawler loaders. Whether for moving material, pushing or grading, the Generation 6 of Liebherr crawler loaders offers powerful machines for every application.

# High Productivity

## Powerful Engines ...

Liebherr diesel engines are designed for the harsh conditions of construction sites and provide the right amount of power in every situation. Depending on the job requirements, different operating modes are available for maximum power or fuel-saving operation.

## ... and an Intelligent Drive System

The hydrostatic travel drive operates smoothly and automatically adjusts the working speed to the required traction. The engine's power is always transmitted to both tracks without interruption. This permits exact and powerful steering; track slip is minimized and operators can concentrate completely on their work.

## Quick Work Cycle and High Tipping Load

The ability to change direction rapidly combined with quick loading cycles guarantees short cycle times and increased productivity. The high tipping load also ensures an impressive level of stability, e.g. when loading trucks.

# Precise Control

## Excellent Maneuverability

When handling materials in a confined space, the hydrostatic travel drive offers an additional benefit. All steering motions – including turning on the spot – are fast and effortless.

## “LUDV” Hydraulic Control Block

Load-Independent Flow Distribution: this technical innovation of Load Sensing into the LUDV-system provides greater sensitivity for the operation of the lift frame. It allows the harmonized execution of concurrent movements, such as simultaneously raising and tipping the bucket. Power adaptation on demand (Load Sensing) continues to be guaranteed.

## The “All-Purpose Machine”

Whether it is extensive landscaping, straightforward materials handling, heavy dozer operation, grading service or ripping operations – Liebherr crawler loaders can always be used for a wide variety of applications.

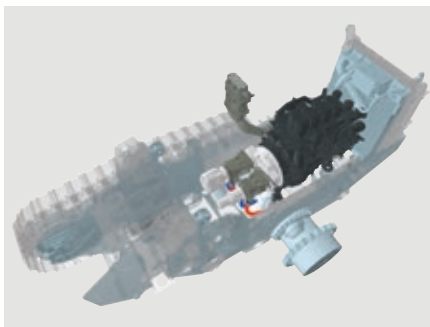

### Liebherr Hydrostatic Drive

- Automatic speed and torque adjustment continuously optimizes transmission of engine power to the tracks as the load changes. This results in maximum traction with minimum track slip.
- The advantages of the drive are particularly revealed in heavy dozing and loading operation.

### Intelligent Engine Control

- The electronically modelled power and torque curves ensure outstanding pulling power and a dynamic response to increasing loads.
- On-demand power boost assures adequate power reserves, even under the most difficult working conditions.

### Powerful Operating Equipment

- Solid Z-kinematics design provides very high break-out forces.
- LUDV-system: optimized hydraulic technology for quicker loading cycles and a high bucket fill level ensure increased productivity.

# Efficiency



## Cost Efficiency Comes Standard

Liebherr crawler loaders are specifically designed for profitability. A highly efficient drive concept, a long service life for components and minimal maintenance efforts keep operating costs down, and increase your returns.

# Unrivalled Economy

## The Latest Engine and Exhaust Technology

The newest generation of Liebherr diesel engines complies with Emission Stage IV/Tier 4 final. Liebherr-SCR technology: the exhaust gas undergoes selective catalytic reduction through injection of urea (DEF, AdBlue®). A diesel particulate filter is not required. As a result, the engine operates in a temperature range of maximum efficiency. The constant, low engine speed, in combination with Common-Rail injection, ensures optimized cylinder charging and, in turn, even more efficient fuel combustion.

## Highly Efficient Driveline

The high efficiency of the hydrostatic drive extends over almost the entire speed range. In combination with the intelligent working hydraulics, the engine's power is transmitted with maximum efficiency and fuel consumption is minimized.

## Lower CO<sub>2</sub> Emissions

With exhaust emission values that comply with the most stringent legislation and even greater fuel economy than that of previous models, the Liebherr LR 636 crawler loader sets new standards for environmental friendliness. The "ecological footprint" is smaller than ever.



# Optimized for Every Job

## Wide Variety of Equipment

The variety of front and rear equipment ensures the perfect configuration for every application: standard bucket, 4-in-1 bucket, waste handling bucket, rear ripper, winch and draw-bar are all available.

## Undercarriage with Rotary Bushings

As the perfect feature when working on very abrasive ground, Liebherr offers a track assembly with free-turning bushings (FTB). The large, free-turning bushings minimize track and sprocket wear; in addition, chain links and rollers have even more wear material. This extends the service life of the entire track assembly considerably in these specific applications.

## Equipment for Special Applications

Applications such as handling of waste materials place major demands on the versatility and toughness of the machines. Specially developed equipment kits ensure maximum efficiency and a long service life, even under these harsh operating conditions.

### Eco-Mode

- The selectable Eco-Mode reduces the engine speed at the press of a button and additionally lowers fuel consumption. Ideal for medium and light weight duty.
- If the machine idles for an extended period of time, the engine can shut down automatically and avoid wasting fuel needlessly (optional).

### LR 636 Landfill Kit

- Liebherr offers a fully equipped variant of the LR 636 for use on landfills.
- Many components have been developed especially for use on landfills and provide optimum protection as well as long service life.

### Always Informed with LiDAT

- The Liebherr LiDAT data transmission and positioning system contributes to effective fleet management.
- Utilizing the latest communication technology, LiDAT provides extensive information on machine operation and in this way ensures economical management, optimized service call scheduling and remote monitoring.

# Reliability



## Robust Design in Every Regard

Today's construction sites require machines with maximum versatility and ruggedness. Crawler loaders from Liebherr meet these requirements in an ideal manner: Thanks to components designed specifically for construction machinery, proven technology and innovative customer-specific solutions, you can expect maximum availability.



# Liebherr Driveline

## Long-Lasting Engines

Diesel engines from Liebherr have powered construction machinery around the world for decades. Developed for the harshest operating conditions, their rugged construction and low nominal operating speed guarantee maximum reliability and a long service life.

## Wear-Free Drive Concept

The proven Liebherr hydrostatic travel drive, with its high performance hydraulic pumps and engines, operates virtually free of wear. Based on over 30 years of experience in crawler loaders, this drive concept also offers the highest level of reliability.

## Long-Lasting Final Drives

The large final drives used in the Liebherr crawler loaders are extremely robust and designed for the heaviest loads. Double mechanical seals with monitoring for leaks ensure reliable operation.

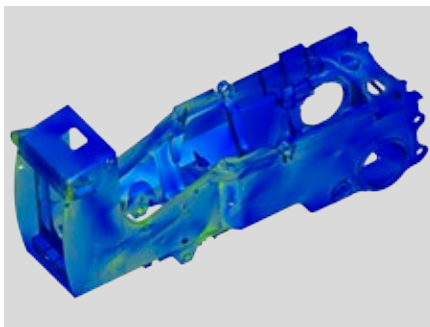

# Rugged Design

## Main Frame with Proven Box-Section Design

The main and track roller frames are constructed in a proven box-section design which provides maximum torsional resistance and optimal absorption of forces. Components subjected to high loads are manufactured from cast steel.

## Optimized Equipment

The lifting frame's tough Z-kinematics and the hard-wearing buckets are made of high-grade steel to ensure machine reliability and durability. The design is low-maintenance as bearing points are accessible from ground level.

The generously dimensioned ripper is ideal and highly effective even in heavy-duty applications, making the Liebherr crawler loaders the ultimate all-rounder on the construction site.

## An Intelligent Cooling System

A hydraulically driven fan is activated on demand to regulate the operating temperature independently of the engine's speed. This guarantees short warm-up times and reliable cooling – even in extremely dusty surroundings. A reversible fan is available for machines operating in special applications.

## From the Screen to the Construction Site

- Optimized layout: Components are analyzed with the aid of the latest development software as early as the design phase.
- Extensive test bench runs are the next important step in the development process.
- Long-term field tests under rigorous test conditions ensure maximum machine availability.

## Key Technologies from Liebherr

- Liebherr has decades of experience in developing, designing and manufacturing components and, as a result, offers maximum reliability.
- Important key components such as diesel engines, distribution gearboxes, hydraulic cylinders, final drives and electronics are manufactured in our own facility, optimized for combined operation and represent the highest quality.

## Liebherr Lubricants and Operating Fluids

- Nowadays lubricants are considered to be a design element and are therefore a major component of all modern construction machines.
- Liebherr offers an extensive range of high quality lubricants and operating fluids. These are designed specifically for use in Liebherr machines and ensure excellent durability for all components with the lowest possible operating costs.

# Comfort



## Comfort, Space and Ergonomics: All in One

The working area in the generation 6 Liebherr crawler loaders is characterized by the exceptional level of comfort offered to the operator. Comfort is provided by the generous space, ergonomic layout, quiet and with the best possible visibility, the Liebherr comfort cab provides the ideal conditions for concentrated work, without fatigue.

## Deluxe Cab

### Ergonomic and Purposely Designed

The well-thought-out design of the operator's cab provides the best conditions for relaxed and productive work.

All instruments and operating controls are organized logically and ergonomically, and are easily reached. An unobstructed view of the work equipment and perfect all-round visibility allows the operator to concentrate fully on the task at hand.

### Convenience in Daily Use

Carefully considered details such as adjustable armrests, a variety of stowage options, a cooled storage compartment and a powerful air conditioning system improve the operator's comfort and boost daily productivity.

### Quiet and Dust-Free

Thanks to effective sound insulation and modern, low-noise diesel engines, the Liebherr crawler loaders features exemplary noise levels that lie well below the legal limits. The pressurized cab keeps the operator's environment free of dust from the surroundings.

## Simple and Intuitive Operation

### Single-Lever Control

All driving functions can be controlled smoothly and precisely with only one operating lever – including the “turning on the spot” function. The travel joystick is optionally available in either a proportional or “V-lever” version including foot-pedal steering – this allows control to be matched optimally to the needs of the operator.

### Safety-Plus Comfort Seat

The standard air-sprung seat adjusts perfectly to the operator and deactivates the machine automatically on exiting the cab.

### The Hydrostatic Drive as Service Brake

The crawler loader never loses traction even when driving on slopes. Thanks to the self-locking nature of the hydrostatic drive system, the operator can bring the machine to a stop at any time simply by bringing the joystick to the “neutral” position. An automatically activated parking brake provides additional safety.



### Individual Set-Up

- The intuitive touch-screen display continuously provides all important operating data.
- At the same time, the display screen also serves as a monitor for the reversing camera.
- At the push of a button, the operator can adjust a wide variety of machine settings – e.g., the response of the travel drive – precisely to his needs.

### Visibility = Safety

- The reversing camera comes standard and increases the operator's field of vision and enhances safety on the construction site as well as helping to improve productivity when using the ripper.
- The camera is permanently active and when reversing, the image can be selected in either small or large format.

### Panoramic Windows

- A plus for safety and productivity: the front screen extends a long way down to give the best possible view of the working equipment.
- The cab's integrated ROPS/FOPS protection also ensures unmatched all-round visibility.

# Maintainability

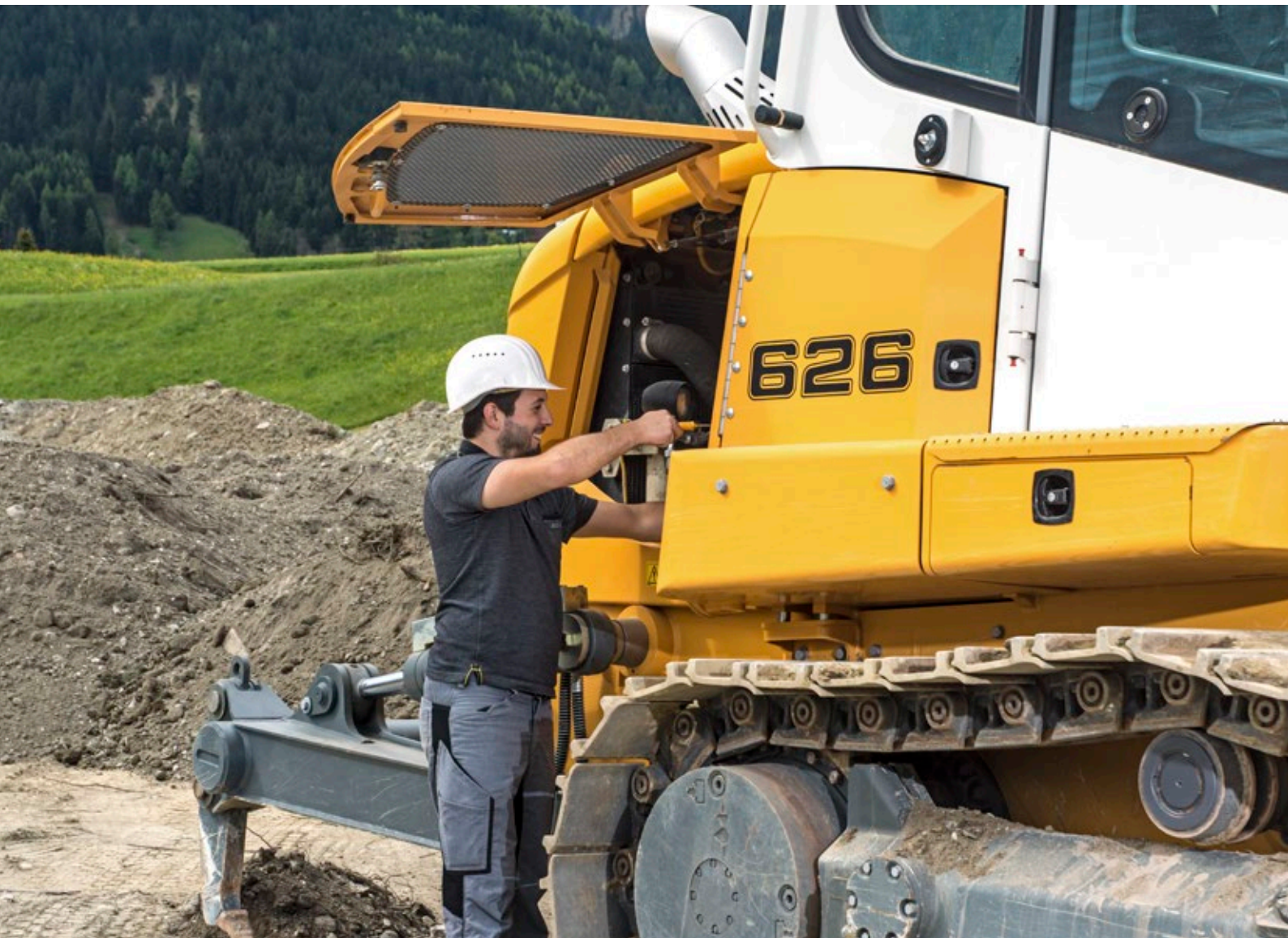

## Simple Maintenance and an Extensive Service Network

Thanks to their minimal maintenance requirements, Liebherr crawler loaders make a reliable contribution to your economic success. A dense service network means short distances, efficient structures and fast service response times for the user.

## Cost-Effective Maintenance

### Simple Daily Checks

All items that the operator checks during daily routine inspections are readily accessible on one side of the engine. The hydraulically tilted cab comes as standard and provides easy access to components as well. Service work can be performed quickly and efficiently.

### Long Maintenance Intervals

The maintenance intervals are optimally matched to the individual components. Maintenance-free mountings are often used in exposed areas. Hydraulic oil change intervals of up to 8,000 operating hours reduce costs and minimize downtime.

## Optimal Planning

### Planned Costs

Liebherr crawler loaders come with extensive standard warranties for the entire machine and the drive train. Customized inspection and service programmes allow optimal planning of all maintenance activities.

### Remanufacturing

The Liebherr remanufacturing program offers cost-effective reconditioning of components to the highest quality standards. Various reconditioning levels are available: Replacement components, general overhaul or repair. The customer receives components with original part quality at a reduced cost.

## The Focus is on the Customer

### Qualified Advice and Service

Competent advice is given at Liebherr. Experienced specialist provide adequate guidance for your specific requirements: application-oriented sales support, service agreements, value-priced repair alternatives, original parts management, as well as remote data transmission for machine planning and fleet management.

### Continuous Dialogue with Users

We utilize the expert knowledge and practical experience of our customers to consistently optimize our machines and services – real solutions for real situations.



### Easy Access

- All service points are centrally located and easily accessible. Thanks to wide-opening access doors, the daily inspection of the machine is simple and time-saving.
- The standard lighting of the engine area simplifies maintenance and inspection.

### Tilt-Out Cooling Fan

- In especially dusty applications, the standard swing-out fan contributes significantly to easy cleaning of the radiator system. The HD radiator grille requires no tools to open.

### Rapid Spare Parts Service

- 24-hour delivery: Spare parts service is available for our dealers around the clock.
- Electronic spare parts catalogue: Fast and reliable selection and ordering via the Liebherr online portal.
- With online tracking, the current processing status of your order can be viewed at any time.

# Technical Data LR 626



## Engine

<b>Liebherr Diesel engine</b>	D 924-A7-04 Emission regulations according to 97/68/EC, 2012/46/EU Stage IV, EPA/CARB Tier 4f
<b>Rated power (net)</b>	
ISO 9249	105 kW/ 143 HP
SAE J1349	105 kW/ 141 HP
<b>Maximum power (net)</b>	
ISO 9249	120 kW/ 163 HP
SAE J1349	120 kW/ 161 HP
<b>Rated speed</b>	2,100 rpm
<b>Displacement</b>	4.5 l/ 275 in <sup>3</sup>
<b>Bore/stroke</b>	104 mm (4.09 in)/ 132 mm (5.2 in)
<b>Design</b>	4 cylinder in-line engine, water-cooled, turbocharged, air-to-air intercooler
<b>Injection system</b>	Direct fuel injection, Common Rail, electronic control
<b>Lubrication</b>	Pressurised lube system, engine lubrication guaranteed for inclinations up to 45°, on all sides
<b>Operating voltage</b>	24 V
<b>Alternator</b>	140 A
<b>Starter</b>	5.5 kW/ 7 HP
<b>Batteries</b>	2 x 180 Ah/ 12 V
<b>Air cleaner</b>	Dry-type air cleaner with pre-cleaner and automatic dust ejector, main and safety elements with radial seal
<b>Cooling system</b>	Combination cooler with single cooling units for water, hydraulic oil and intake charge air
<b>Cooling fan</b>	Hydrostatically driven, thermostatically controlled



## Hydraulics

<b>Hydraulic system</b>	LUDV-system
<b>Pump type</b>	Variable displacement pump (swash-plate design)
<b>Pump flow max.</b>	155 l/min. / 40.9 gpm / 34.1 Imp.gpm
<b>Pressure limitation</b>	260 bar / 3,770 psi
<b>Filter system</b>	Return filter with magnetic rod in hydraulic tank
<b>Control</b>	Single joystick implement control for all bucket functions, with magnetic detent functions for float position as well as for automatic bucket positioner and for automatic lift kickout



## Travel Drive, Control

<b>Transmission system</b>	Closed-loop infinitely variable hydrostatic travel drive powered by two axial piston variable displacement pumps and two axial piston variable displacement motors in swash-plate design, each track is driven independently from each other
<b>Travel speed*</b>	Continuously variable
Speed range 1 (reverse):	0 – 4.0 km/h/ 2.5 mph (4.5 km/h/ 2.8 mph)
Speed range 2 (reverse):	0 – 6.5 km/h/ 4.0 mph (8.0 km/h/ 4.9 mph)
Speed range 3 (reverse):	0 – 10.0 km/h/ 6.2 mph (10.0 km/h/ 6.2 mph)
	* Travel speed ranges can be set on the travel joystick
<b>Electronic control</b>	Electronic engine speed sensing control (load-sensing feature) automatically adjusts travel speed and drawbar pull to match changing load conditions
<b>Steering</b>	Hydrostatic, unlimited manoeuvrability for full power turns and counterrotation
<b>Service brake</b>	Hydrostatic, dynamic braking effect from travel drive system
<b>Parking/ emergency brake</b>	Multi-disc brake, wear-free, automatically applied with neutral joystick position
<b>Cooling system</b>	Hydraulic oil single unit built in combination cooler
<b>Filter system</b>	Micro cartridge filters in replenishing circuit
<b>Final drive</b>	Combination spur gear with planetary gear, double sealed (duo cone seals) with electronic seal-integrity indicator
<b>Control</b>	Single joystick for all travel and steering functions, as well as for counterrotation



## Operator's Cab

<b>Cab</b>	Resiliently mounted cab with positive pressure ventilation, can be tilted with hand pump 40° to the rear. With integrated ROPS Rollover Protective Structure (EN ISO 3471) and FOPS Falling Objects Protective Structure (EN ISO 3449).
<b>Operator's seat</b>	Adjustable, suspended seat adjustable to operator's weight
<b>Monitoring</b>	Touch screen: display of current machine information, automatic monitoring of operating conditions. Individual setting of machine parameters

## Undercarriage

<b>Mounting</b>	Pivot shafts and equalizer bar (cushion mounted)
<b>Track chains</b>	Sealed and lubricated, track chain tension via grease tensioner and steel spring
<b>Links, each side</b>	38
<b>Sprocket segments, each side</b>	5
<b>Track rollers, each side</b>	6
<b>Carrier rollers, each side</b>	1
<b>Track shoes, standard</b>	508 mm/20", double grouser
<b>Track shoes, optional</b>	457 mm/18", double grouser 560 mm/22", double grouser Wider track shoes available on demand
<b>Grouser height</b>	35 mm/1.38 in

## Sound Levels

<b>Operator sound exposure ISO 6396</b>	
L <sub>pA</sub> (in the cab)	78 dB(A)
<b>Exterior sound pressure 2000/14/EC</b>	
L <sub>WA</sub> (to the environment)	109 dB(A)

## Refill Capacities

<b>Fuel tank</b>	320 l/84.5 gal/70.4 Imp.gal
<b>Diesel Exhaust Fluid (DEF) tank</b>	49 l/12.09 gal/10.8 Imp.gal
<b>Cooling system</b>	30 l/7.9 gal/6.6 Imp.gal
<b>Engine oil, with filter</b>	19 l/5 gal/4.2 Imp.gal
<b>Hydraulic tank</b>	90 l/23.8 gal/19.8 Imp.gal
<b>Pivot shaft, each side</b>	4.3 l/1.1 gal/0.9 Imp.gal
<b>Final drive, each side</b>	15 l/4 gal/3.3 Imp.gal
<b>Duo cone seal, each side</b>	8 l/2.1 gal/1.8 Imp.gal

## Cycle Times

<b>Lifting</b>	6.2 s
<b>Dumping</b>	3.0 s
<b>Tilting back</b>	3.2 s
<b>Lowering<sup>1)</sup></b>	2.2 s

<sup>1)</sup> Float position and empty bucket

# Dimensions LR 626

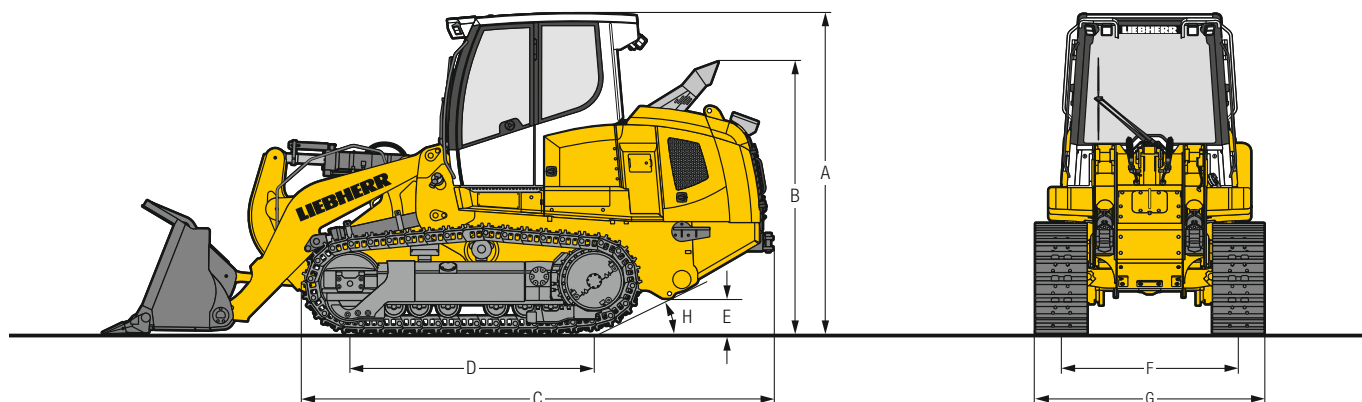

## Dimensions

<b>A</b>	<b>Height over cab</b>	mm	3,150
		ft in	10'4"
<b>B</b>	<b>Height over exhaust pipe</b>	mm	2,688
		ft in	8'10"
<b>C</b>	<b>Length to front of track</b>	mm	4,638
		ft in	15'3"
<b>D</b>	<b>Distance idler / sprocket center</b>	mm	2,405
		ft in	7'11"
<b>E</b>	<b>Ground clearance</b>	mm	420
		ft in	1'5"
<b>F</b>	<b>Track gauge</b>	mm	1,740
		ft in	5'9"
<b>G</b>	<b>Track shoes 457 mm / 18"</b>	mm	2,197
	Machine width	ft in	7'2"
<b>G</b>	<b>Track shoes 508 mm / 20"</b>	mm	2,248
	Machine width	ft in	7'5"
<b>G</b>	<b>Track shoes 560 mm / 22"</b>	mm	2,300
	Machine width	ft in	7'7"
<b>H</b>	<b>Approach angle</b>		30°



# Front Attachments LR 626

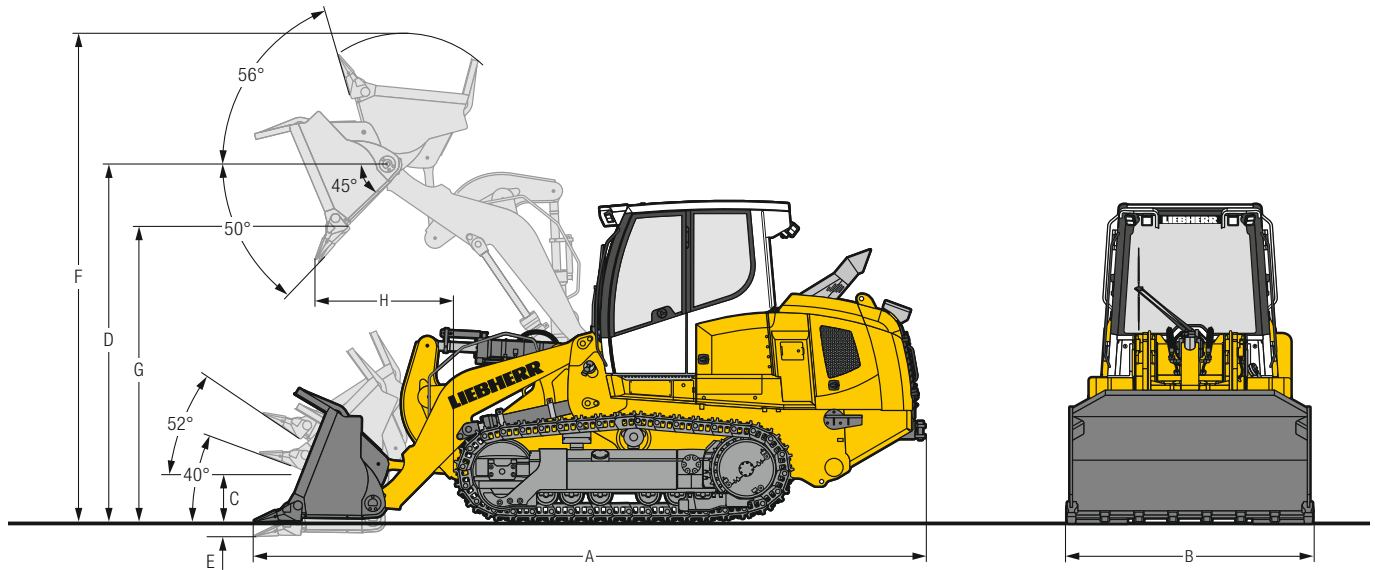

## Standard Bucket

Version with		Bold-on adapters, segments and shanks	Flush mounted weld-on adapters and shanks	Bold-on cutting edge
Nominal rated bucket capacity, ISO 7546	m <sup>3</sup>	1.8	1.7	1.8
	yd <sup>3</sup>	2.35	2.22	2.35
Nominal rated bucket capacity, SAE J742	m <sup>3</sup>	1.8	1.7	1.8
	yd <sup>3</sup>	2.35	2.22	2.35
Breakout force, ISO 14397	kN	127	138	127
	lb	28,541	31,013	28,541
Static tipping load, ISO 14397	kg	11,765	12,011	11,863
	lb	25,937	26,480	26,153
A Overall length bucket at ground with rear bumper	mm	6,337	6,246	6,337
	ft in	20'9"	20'6"	20'9"
B Bucket width, overall <sup>2)</sup>	mm	2,444	2,450	2,420
	ft in	8'0"	8'0"	7'11"
C Height of hinge pin, transport position	mm	541	541	541
	ft in	1'9"	1'9"	1'9"
D Height of hinge pin, max.	mm	3,663	3,663	3,663
	ft in	12'0"	12'0"	12'0"
E Digging depth, max.	mm	136	111	136
	ft in	5.35"	4.37"	5.35"
F Overall height with bucket at full lift	mm	5,007	5,007	5,007
	ft in	16'5"	16'5"	16'5"
G Dump clearance at full lift and 45° discharge, ISO 7131	mm	2,849	2,917	2,849
	ft in	9'4"	9'7"	9'4"
H Reach at full lift and 45° discharge, ISO 7131	mm	1,051	1,018	1,051
	ft in	3'5"	3'4"	3'5"
Bucket weight	kg	1,238	1,126	1,140
	lb	2,729	2,482	2,513
Operating weight <sup>1)</sup>	kg	16,486	16,366	16,546
	lb	36,345	36,081	36,478
Ground pressure <sup>1)</sup>	kg/cm <sup>2</sup>	0.68	0.67	0.67
	psi	9.67	9.53	9.53

<sup>1)</sup> Including coolant and lubricants, full fuel tank, ROPS/FOPS cab, operator, bucket, counterweight and track shoes with 508 mm/20".

<sup>2)</sup> Track shoes with 508 mm/20". With other track shoes on demand at your dealer.

# Front Attachments LR 626

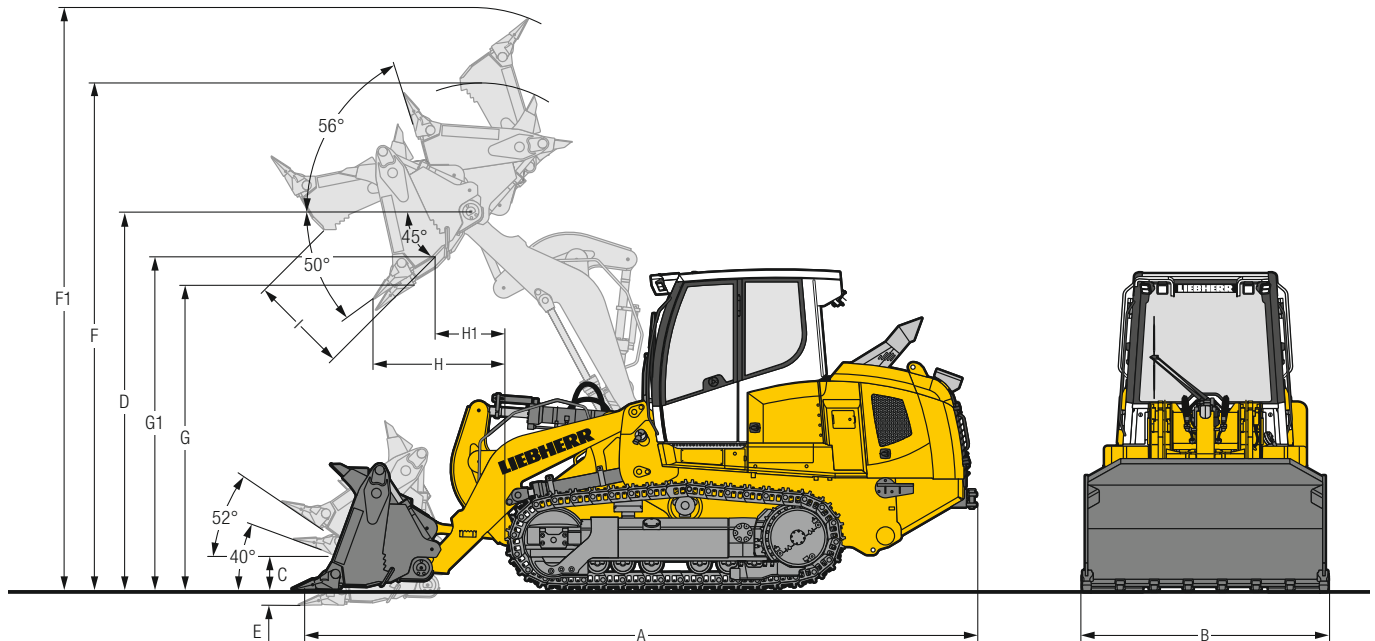

## Multi-Purpose Bucket

Version with		Bolt-on adapters, weld-on adapters and shanks	Flush mounted weld-on adapters and shanks	Bold-on cutting edge
Nominal rated bucket capacity, ISO 7546	m <sup>3</sup> /yd <sup>3</sup>	1.6/2.09	1.5/1.96	1.6/2.09
Nominal rated bucket capacity, SAE J742	m <sup>3</sup> /yd <sup>3</sup>	1.6/2.09	1.5/1.96	1.6/2.09
Breakout force, ISO 14397	kN/lb	113/25,394	123/27,642	113/25,394
Static tipping load, ISO 14397	kg/lb	10,376/22,875	10,610/23,391	10,473/23,089
<b>A</b> Overall length bucket at ground with rear bumper	mm ft in	6,474 21'3"	6,384 20'11"	6,474 21'3"
<b>B</b> Bucket width, overall <sup>2)</sup>	mm ft in	2,448 8'0"	2,450 8'0"	2,420 7'11"
<b>C</b> Height of hinge pin, transport position	mm ft in	541 1'9"	541 1'9"	541 1'9"
<b>D</b> Height of hinge pin, max.	mm ft in	3,663 12'0"	3,663 12'0"	3,663 12'0"
<b>E</b> Digging depth, max.	mm ft in	186 7.32"	161 6.34"	186 7.32"
<b>F</b> Overall height with bucket at full lift (bucket closed)	mm ft in	5,015 16'5"	5,015 16'5"	5,015 16'5"
<b>F1</b> Overall height with bucket at full lift (bucket open)	mm ft in	5,591 18'4"	5,523 18'1"	5,591 18'4"
<b>G</b> Dump clearance at full lift and 45° discharge (bucket), ISO 7131	mm ft in	2,743 9'	2,811 9'3"	2,743 9'
<b>G1</b> Dump clearance at full lift and 45° discharge (blade), ISO 7131	mm ft in	3,253 10'8"	3,253 10'8"	3,253 10'8"
<b>H</b> Reach at full lift and 45° discharge (bucket), ISO 7131	mm ft in	1,086 3'7"	1,053 3'5"	1,086 3'7"
<b>H1</b> Reach at full lift and 45° discharge (blade), ISO 7131	mm ft in	625 2'1"	625 2'1"	625 2'1"
<b>I</b> Width of opening	mm/ft in	1,201/3'11"	1,201/3'11"	1,201/3'11"
Bucket weight	kg/lb	1,782/3,929	1,671/3,684	1,685/3,715
Operating weight <sup>1)</sup>	kg/lb	17,216/37,955	17,172/37,858	17,164/37,840
Ground pressure <sup>1)</sup>	kg/cm <sup>2</sup> /psi	0.71/10.1	0.70/9.95	0.70/9.95

<sup>1)</sup> Including coolant and lubricants, full fuel tank, ROPS/FOPS cab, operator, bucket, counterweight and track shoes with 508 mm/20".

<sup>2)</sup> Track shoes with 508 mm/20". With other track shoes on demand at your dealer.

# Rear Attachments LR 626

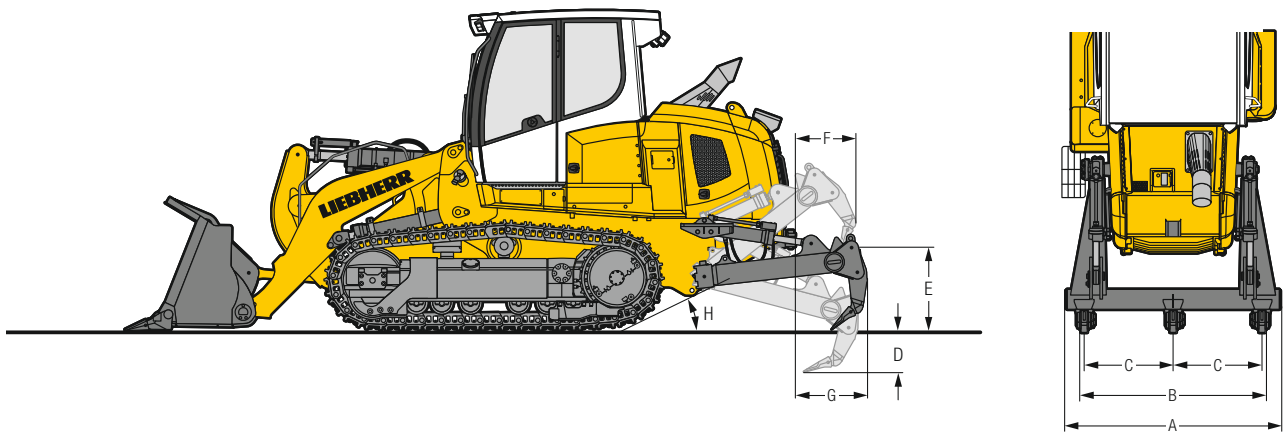

## 3-Shank Ripper Radial

<b>A</b>	<b>Beam width</b>	mm	2,096
		ft in	6'11"
<b>B</b>	<b>Ripping width</b>	mm	1,800
		ft in	5'11"
<b>C</b>	<b>Distance between shanks</b>	mm	870
		ft in	2'10
<b>D</b>	<b>Penetration max.</b>	mm	348
		ft in	1'2"
<b>E</b>	<b>Ground clearance, max. below shanks</b>	mm	715
		ft in	2'4"
<b>F</b>	<b>Additional length, ripper raised</b>	mm	638
		ft in	2'1"
<b>G</b>	<b>Additional length, transport position</b>	mm	769
		ft in	2'6"
<b>H</b>	<b>Approach angle, ripper raised</b>		20°
	<b>Ripper weight<sup>1)</sup></b>	kg	919
		lb	2,026
	<b>Change in operating weight</b>	kg	876
		lb	1,931
	<b>Change in ground pressure</b>	kg/cm <sup>2</sup>	0.03
		psi	0.43
	<b>Change in static tipping load</b>	kg	1,859
		lb	4,098

<sup>1)</sup> If the ripper is mounted, no counterweight will be fitted to the machine.

# Technical Data LR 636



## Dieselmotor

<b>Liebherr Diesel engine</b>	D 934 A7 Emission regulations according to 97/68/EC, 2012/46/EU Stage IV, EPA/CARB Tier 4f
<b>Rated power (net)</b>	
ISO 9249	135 kW/ 184 HP
SAE J1349	135 kW/ 184 HP
<b>Maximum power (net)</b>	
ISO 9249	160 kW/218 HP
SAE J1349	160 kW/214 HP
<b>Rated speed</b>	1.800 1/min.
<b>Displacement</b>	7.0 l / 427 in <sup>3</sup>
<b>Bore/stroke</b>	122 mm (4.80 in)/ 150 mm (5.91 in)
<b>Design</b>	4 cylinder in-line engine, water-cooled, turbocharged, air-to-air intercooler
<b>Injection system</b>	Direct fuel injection, Common Rail, electronic control
<b>Lubrication</b>	Pressurized lube system, engine lubrication guaranteed for inclinations up to 45°, on all sides
<b>Operating voltage</b>	24 V
<b>Alternator</b>	140 A
<b>Starter</b>	7.8 kW/ 11 HP
<b>Batteries</b>	2 x 180 Ah/ 12 V
<b>Air cleaner</b>	Dry-type air cleaner with pre-cleaner and automatic dust ejector, main and safety elements with radial seal
<b>Cooling system</b>	Combination cooler with single cooling units for water, hydraulic oil and intake charge air
<b>Cooling fan</b>	Hydrostatically driven, thermostatically controlled



## Hydraulics

<b>Hydraulic system</b>	LUDV-system
<b>Pump type</b>	Variable displacement pump (swash-plate design)
<b>Pump flow max.</b>	209 l/min. / 55.2 gpm / 46.0 Imp.gpm
<b>Pressure limitation</b>	260 bar / 3,770 psi
<b>Filter system</b>	Return filter with magnetic rod in hydraulic tank
<b>Control</b>	Single joystick implement control for all bucket functions, with magnetic detent functions for float position as well as for automatic bucket positioner and for automatic lift kickout



## Travel Drive, Control

<b>Transmission system</b>	Closed-loop infinitely variable hydrostatic travel drive powered by two axial piston variable displacement pumps and two axial piston variable displacement motors in swash-plate design, each track is driven independently from each other
<b>Travel speed*</b>	Continuously variable
Speed range 1 (reverse):	0 – 4.0 km/h / 2.5 mph (4.5 km/h / 2.8 mph)
Speed range 2 (reverse):	0 – 6.5 km/h / 4.0 mph (8.0 km/h / 4.9 mph)
Speed range 3 (reverse):	0 – 11.0 km/h / 6.8 mph (11.0 km/h / 6.8 mph)
	* Travel speed ranges can be set on the travel joystick
<b>Electronic control</b>	Electronic engine speed sensing control (load-sensing feature) automatically adjusts travel speed and drawbar pull to match changing load conditions
<b>Steering</b>	Hydrostatic, unlimited manoeuvrability for full power turns and counterrotation
<b>Service brake</b>	Hydrostatic, dynamic braking effect from travel drive system
<b>Parking/ emergency brake</b>	Multi-disc brake, wear-free, automatically applied with neutral joystick position
<b>Cooling system</b>	Hydraulic oil cooler integrated into combination cooler
<b>Filter system</b>	Micro cartridge filters in replenishing circuit
<b>Final drive</b>	Combination spur gear with planetary gear, double sealed (duo cone seals) with electronic seal-integrity indicator
<b>Control</b>	Single joystick for all travel and steering functions, as well as for counterrotation



## Operator's Cab

<b>Cab</b>	Resiliently mounted cab with positive pressure ventilation, can be tilted with hand pump 40° to the rear. With integrated ROPS Rollover Protective Structure (EN ISO 3471) and FOPS Falling Objects Protective Structure (EN ISO 3449).
<b>Operator's seat Monitoring</b>	Air-suspended comfort seat, fully adjustable Touch screen: display of current machine information, automatic monitoring of operating conditions. Individual setting of machine parameters

## Undercarriage

<b>Mounting</b>	Pivot shafts and equalizer bar (cushion mounted)
<b>Track chains</b>	Sealed and lubricated, track chain tension via grease tensioner and steel spring
<b>Links, each side</b>	38
<b>Sprocket segments, each side</b>	5
<b>Track rollers, each side</b>	6
<b>Carrier rollers, each side</b>	1
<b>Track shoes, standard</b>	560 mm / 22", double grouser
<b>Track shoes, optional</b>	508 mm / 20", double grouser 610 mm / 24", double grouser Wider track shoes available on demand
<b>Grouser height</b>	42.5 mm / 1.67 in



## Sound Levels

<b>Operator sound exposure ISO 6396</b>	
L <sub>PA</sub> (in the cab)	78 dB(A)
<b>Exterior sound pressure 2000/14/EC</b>	
L <sub>WA</sub> (to the environment)	110 dB(A)



## Refill Capacities

<b>Fuel tank</b>	400 l / 105.6 gal / 88 Imp.gal
<b>Diesel Exhaust Fluid (DEF) tank</b>	49 l / 12.9 gal / 10.8 Imp.gal
<b>Cooling system</b>	42 l / 11.1 gal / 9.2 Imp.gal
<b>Engine oil, with filter</b>	29 l / 7.7 gal / 6.4 Imp.gal
<b>Splitter box</b>	5.3 l / 1.4 gal / 1.2 Imp.gal
<b>Hydraulic tank</b>	86 l / 22.7 gal / 18.9 Imp.gal
<b>Pivot shaft, each side</b>	5 l / 1.3 gal / 1.1 Imp.gal
<b>Final drive, each side</b>	20 l / 5.3 gal / 4.4 Imp.gal
<b>Duo cone seal, each side</b>	9.5 l / 2.5 gal / 2.1 Imp.gal



## Cycle Times

<b>Lifting</b>	6.4 s
<b>Dumping (at max. height)</b>	1.5 s
<b>Tilting back (at max. height)</b>	2.0 s
<b>Lowering<sup>1)</sup></b>	2.6 s

<sup>1)</sup> Float position and empty bucket

# Dimensions LR 636

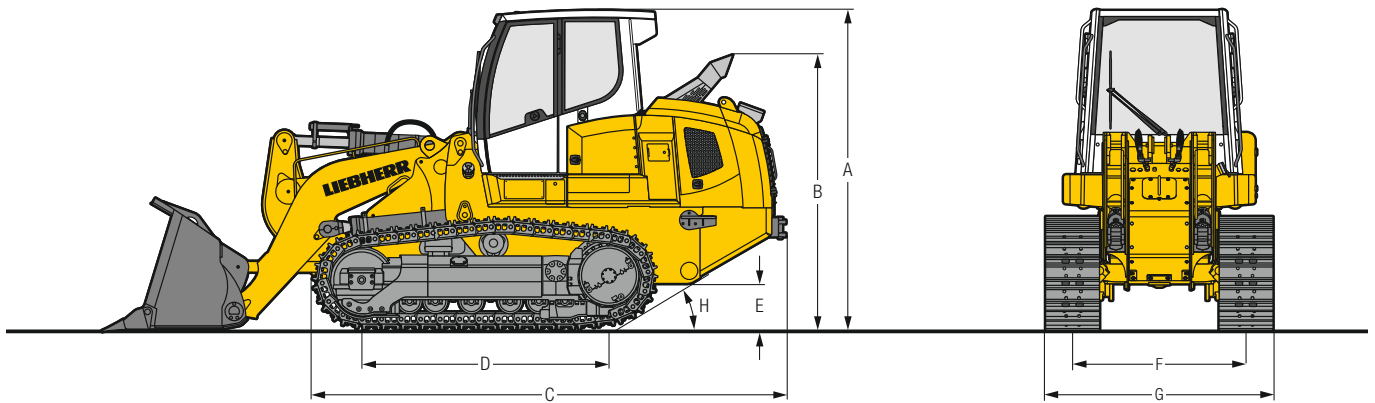

## Dimensions

<b>A</b>	<b>Height over cab</b>	mm	3,330
		ft in	10'11"
<b>B</b>	<b>Height over exhaust pipe</b>	mm	2,866
		ft in	9'5"
<b>C</b>	<b>Length to front of track</b>	mm	4,940
		ft in	16'2"
<b>D</b>	<b>Distance idler / sprocket center</b>	mm	2,580
		ft in	8'6"
<b>E</b>	<b>Ground clearance</b>	mm	483
		ft in	1'7"
<b>F</b>	<b>Track gauge</b>	mm	1,800 <sup>1)</sup>
		ft in	5'11"
<b>G</b>	<b>Track shoes 508 mm / 20"</b>	mm	2,308
	Machine width	ft in	7'7"
<b>G</b>	<b>Track shoes 560 mm / 22"</b>	mm	2,360
	Machine width	ft in	7'9"
<b>G</b>	<b>Track shoes 610 mm / 24"</b>	mm	2,550
	Machine width	ft in	8'4"
<b>H</b>	<b>Approach angle</b>		30°

<sup>1)</sup> Track guard with 610 mm / 24" track shoes: 1,940 mm / 6'4"

# Front Attachments LR 636

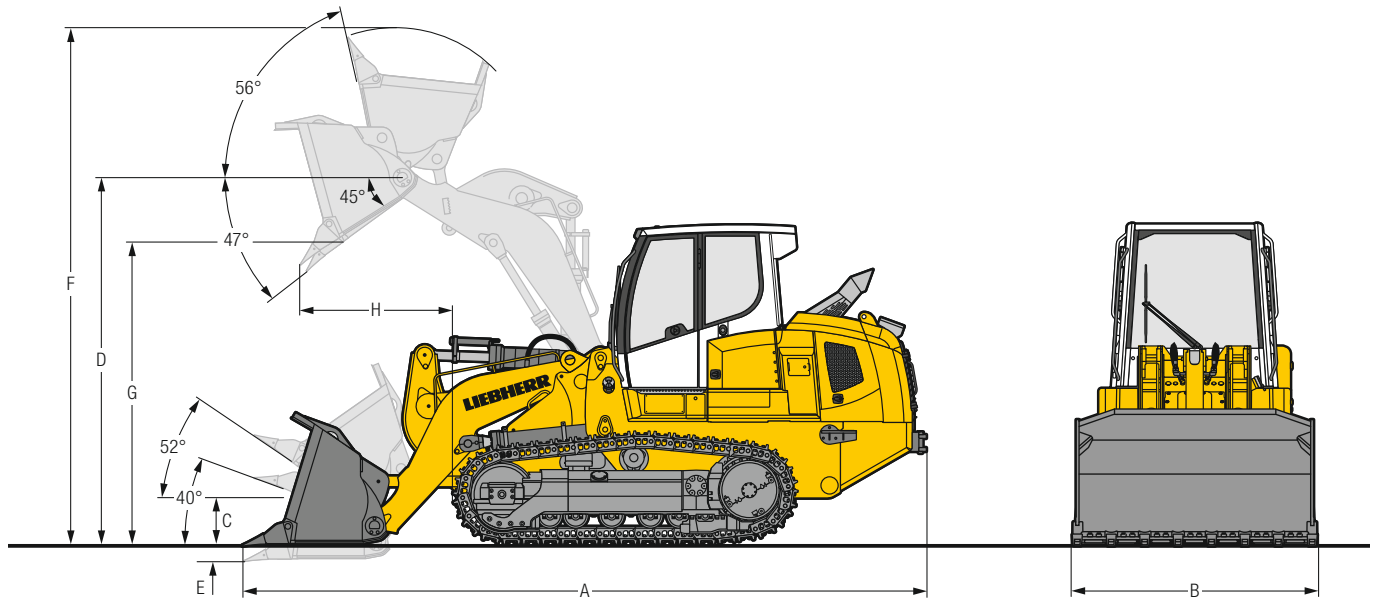

## Standard Bucket

Version with		Bolt-on adapters, segments and shanks	Flush mounted weld-on adapters and shanks	Bolt-on cutting edge
Nominal rated bucket capacity, ISO 7546	m <sup>3</sup>	2.4	2.3	2.4
	yd <sup>3</sup>	3.14	3.01	3.14
Nominal rated bucket capacity, SAE J742	m <sup>3</sup>	2.5	2.3	2.5
	yd <sup>3</sup>	3.27	3.01	3.27
Breakout force, ISO 14397	kN	164	180	164
Static tipping load, ISO 14397	kg	36,856	40,451	36,856
	lb	14,571	14,393	14,731
A Overall length bucket at ground with rear bumper	mm	32,124	31,731	32,476
	ft in	6,984	6,868	6,984
B Bucket width, overall <sup>2)</sup>	mm	22'1"	22'6"	22'11"
	ft in	2,529	2,500	2,490
C Height of hinge pin, transport position	mm	8'4"	8'2"	8'2"
	ft in	576	576	576
D Height of hinge pin, max.	mm	1'11"	1'11"	1'11"
	ft in	4,051	4,051	4,051
E Digging depth, max.	mm	13'4"	13'4"	13'4"
	ft in	151	121	151
F Overall height with bucket at full lift	mm	5.94"	4.76"	5.94"
	ft in	5,477	5,477	5,477
G Dump clearance at full lift and 45° discharge, ISO 7131	mm	18'	18'	18'
	ft in	3,059	3,146	3,059
H Reach at full lift and 45° discharge, ISO 7131	mm	10'0"	10'4"	10'0"
	ft in	1,244	1,195	1,244
Bucket weight	mm	4'1"	3'11"	4'1"
	kg	1,705	1,539	1,585
Operating weight <sup>1)</sup>	lb	3,759	3,393	3,494
	kg	21,587	21,074	21,467
Ground pressure <sup>1)</sup>	lb	47,591	46,460	47,327
	kg/cm <sup>2</sup>	0.75	0.73	0.74
	psi	10.67	10.38	10.52

<sup>1)</sup> Including coolant and lubricants, full fuel tank, ROPS/FOPS cab, operator, bucket, counterweight(s) and track shoes with 560 mm/22".

<sup>2)</sup> Track shoes with 560 mm/22". With other track shoes on demand at your dealer.

# Front Attachments LR 636

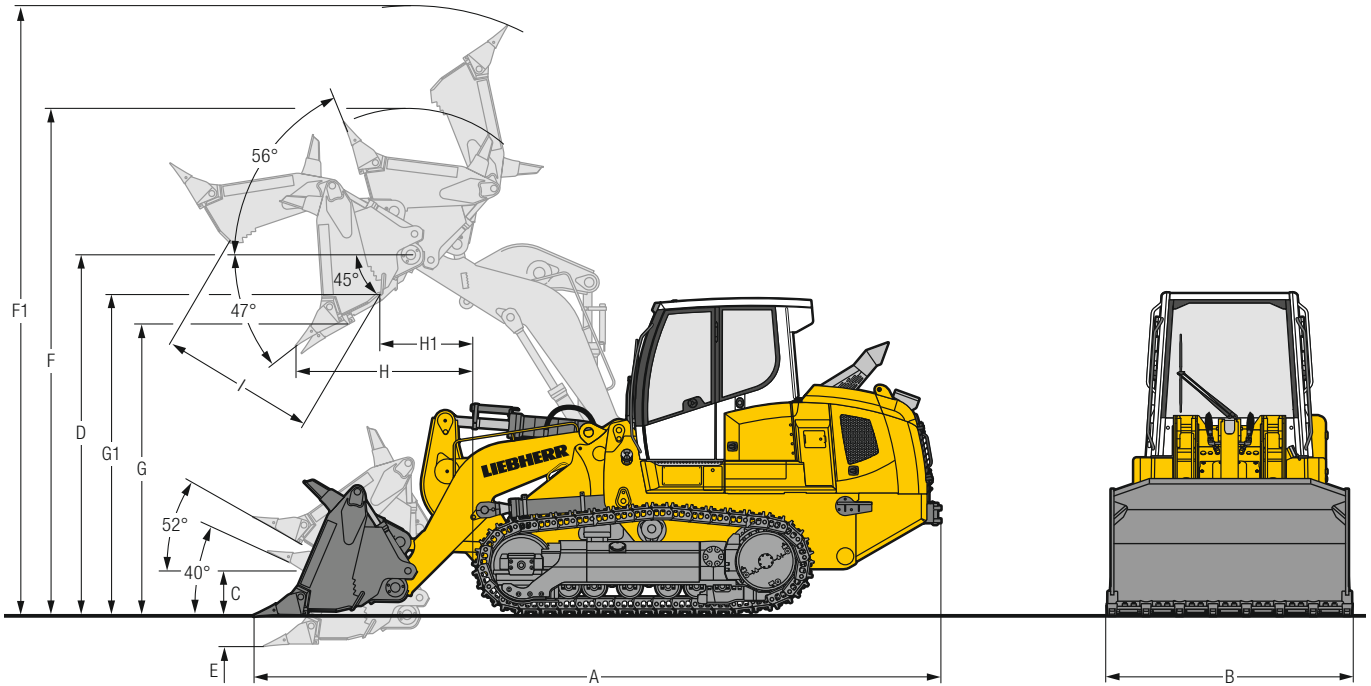

## Multi-Purpose Bucket

Version with		Bolt-on adapters, weld-on adapters and shanks	Flush mounted weld-on adapters and shanks	Bold-on cutting edge
Nominal rated bucket capacity, ISO 7546	m <sup>3</sup> /yd <sup>3</sup>	2.0/2.62	1.9/2.49	2.0/2.62
Nominal rated bucket capacity, SAE J742	m <sup>3</sup> /yd <sup>3</sup>	2.1/2.75	1.9/2.49	2.1/2.75
Breakout force, ISO 14397	kN/lb	155/34,833	169/37,979	155/34,833
Static tipping load, ISO 14397	kg/lb	12,646/27,880	13,038/28,744	12,801/28,221
<b>A</b> Overall length bucket at ground with rear bumper	mm ft in	7,094 23'3"	6,978 22'11"	7,094 23'3"
<b>B</b> Bucket width, overall <sup>2)</sup>	mm ft in	2,529 8'4"	2,500 8'2"	2,490 8'2"
<b>C</b> Height of hinge pin, transport position	mm ft in	576 1'11"	576 1'11"	576 1'11"
<b>D</b> Height of hinge pin, max.	mm ft in	4,051 13'3"	4,051 13'3"	4,051 13'3"
<b>E</b> Digging depth, max.	mm ft in	220 8.66"	190 7.48"	220 8.66"
<b>F</b> Overall height with bucket at full lift (bucket closed)	mm ft in	5,458 17'11"	5,458 17'11"	5,458 17'11"
<b>F1</b> Overall height with bucket at full lift (bucket open)	mm ft in	6,160 20'3"	6,070 19'11"	6,160 20'3"
<b>G</b> Dump clearance at full lift and 45° discharge (bucket), ISO 7131	mm ft in	2,966 9'9"	3,053 10'0"	2,966 9'9"
<b>G1</b> Dump clearance at full lift and 45° discharge (blade), ISO 7131	mm ft in	3,576 12'9"	3,576 11'9"	3,576 11'9"
<b>H</b> Reach at full lift and 45° discharge (bucket), ISO 7131	mm ft in	1,238 4'1"	1,189 3'11"	1,238 4'1"
<b>H1</b> Reach at full lift and 45° discharge (blade), ISO 7131	mm ft in	691 2'3"	691 2'3"	691 2'3"
<b>I</b> Width of opening	mm/ft in	1,290/4'3"	1,290/4'3"	1,290/4'3"
Bucket weight	kg/lb	2,281/5,029	2,115/4,751	2,161/4,764
Operating weight <sup>1)</sup>	kg/lb	21,879/48,235	21,711/47,865	21,759/47,970
Ground pressure <sup>1)</sup>	kg/cm <sup>2</sup> /psi	0.76/10.81	0.75/10.67	0.75/10.67

<sup>1)</sup> Including coolant and lubricants, full fuel tank, ROPS/FOPS cab, operator, bucket, counterweight and track shoes with 508 mm/20".

<sup>2)</sup> Track shoes with 508 mm/20". With other track shoes on demand at your dealer.



# Rear Attachments LR 636

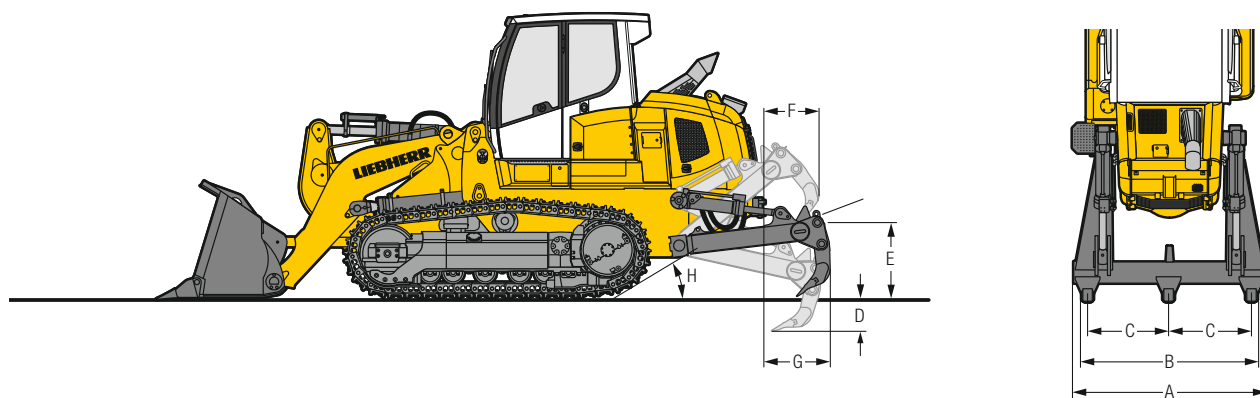



## 3-Shank Ripper Radial

In combination with		Standard bucket up to 3.01 yd <sup>3</sup>	Standard bucket greater than 3.01 yd <sup>3</sup>	Multi-purpose bucket (all sizes)
<b>A</b> Beam width	mm	2,100	2,100	2,100
	ft in	6'11"	6'11"	6'11"
<b>B</b> Ripping width	mm	1,860	1,860	1,860
	ft in	6'1"	6'1"	6'1"
<b>C</b> Distance between shanks	mm	900	900	900
	ft in	2'11"	2'11"	2'11"
<b>D</b> Penetration max.	mm	365	365	365
	ft in	1'2"	1'2"	1'2"
<b>E</b> Ground clearance, max. below shanks	mm	883	883	883
	ft in	2'11"	2'11"	2'11"
<b>F</b> Additional length, ripper raised	mm	604	604	604
	ft in	2'	2'	2'
<b>G</b> Additional length, transport position	mm	715	715	715
	ft in	2'4"	2'4"	2'4"
<b>H</b> Approach angle, ripper raised		21°	21°	21°
	<b>Ripper weight<sup>1)</sup></b>			
<b>Change in operating weight</b>	kg	1,106	1,106	1,106
	lb	2,438	2,438	2,438
<b>Change in ground pressure</b>	kg /cm <sup>2</sup>	0.03	0.02	0.03
	psi	0.43	0.28	0.43
<b>Change in static tipping load</b>	kg	1,897	1,285	1,762
	lb	4,182	2,833	3,885

<sup>1)</sup> If the ripper is mounted, no counterweight will be fitted to the machine.

# Equipment

 <b>Base Machine</b>	LR 626	LR 636
Auto Idle	+	+
Central lubrication system	+	+
Cover plate turbocharger	-	+
Diesel particulate filter	-	+
Dry type air filter dual step, with pre-filter and automatic dust ejector	•	•
Engine compartment doors, lockable	•	•
Fan, hinged	•	•
Fan, hydraulically driven	•	•
Fan, reversible	+	+
Fuel pre-filter	•	•
Fuel pre-filter, with electric heater	+	+
Landfill arrangement	<sup>1)</sup>	+
LiDAT – Data transmission system	•	•
Liebherr diesel engine emission stage IV/Tier 4f	•	•
Liebherr hydraulic oil, biologically degradable	+	+
Lugs for crane lifting, front	•	•
Lugs for crane lifting, rear	•	•
Radiator guard Heavy Duty, hinged	•	•
Radiator, wide-meshed	•	•
Special paint	+	+
Tank guard	+	+
Tool kit, basic	•	•
Tool kit, extended	+	+
Towing hitch, front	•	•
Towing hitch, rear	•	•
Tunnel arrangement	-	+

 <b>Hydraulics</b>	LR 626	LR 636
Automatic lift kickout	•	•
Automatic tilt kickout	•	•
Bucket float function	•	•
Bucket quick drop function	•	•
Hydraulic kit for multi-purpose bucket	+	+
LUDV-system	•	•
Oil filter in hydraulic tank	•	•

 <b>Travel drive</b>	LR 626	LR 636
Emergency stop	•	•
Final drives planetary gear	•	•
Inch brake pedal	+	+
Load limit control, electronic	•	•
Machine-release switch	•	•
Parking brake, automatic	•	•
Seat contact switch	•	•
Travel control, 3 speed ranges	•	•
Travel drive joystick, proportional	•	•
Travel drive, hydrostatic	•	•
V-pattern travel control with steering pedals	+	+

 <b>Operator's Cab</b>	LR 626	LR 636
Air conditioner	•	•
Armrests 2D, adjustable	•	•
Cab tilting system	•	•
Coat hook	•	•
Condenser unit pivoted	+	+
Dome light	•	•
Fire extinguisher	+	+
Mechanical suspension seat	+	+
Operator's seat Comfort, air-suspended	•	•
Operator's seat Premium, air-suspended	+	+
Polycarbonate front screen	+	+
Polycarbonate rear screen	+	+
Pressurised cab	•	•
Protective grid, rear window	+	+
Radio	+	+
Radio preparation kit	•	•
Rear-view camera	•	•
Rear-view mirror, inside	+	+
Rear-view mirror, outside	+	+
ROPS/FOPS integrated	•	•
Safety glass, tinted	•	•
Sliding window left	•	•
Sliding window right	•	•
Socket 12 V	•	•
Socket 24 V	•	•
Speed switch, work/travel modes	•	•
Stowage compartment, air-conditioned	•	•
Sunblind, front	•	•
Warm water heating	•	•
Windshield washer system	•	•
Windshield wipers front and rear, with intermittent function	•	•

- = Standard
- + = Option
- = not available
- <sup>1)</sup> on demand at your dealer



## Electrical System

	LR 626	LR 636
2 additional working lights on the cab, rear	+	+
2 cold start batteries	•	•
2 working lights on the cab, rear	•	•
4 working lights on the cab, front	•	•
All working lights in LED version	+	+
Amber beacon	+	+
Back-up alarm	+	+
Back-up alarm, switchable	+	+
Battery main switch	•	•
Horn	•	•
Immobiliser, electronic	+	+
On-board voltage 24 V	•	•



## Undercarriage

	LR 626	LR 636
Idler-deflector	•	•
Master link, two-piece	•	•
Rear striker bar	+	+
Sprocket segments with recesses	+	+
Sprocket segments, bolted	•	•
Sprocket-deflector	•	•
Track frame, closed	•	•
Track guard, full length	+	+
Track guide, centre part	+	+
Track guides, front and rear	•	•
Track pads with mud holes	+	+
Track shoes, moderate service	•	•
Tracks, oil-lubricated	•	•
Undercarriage LGP	+	+
Undercarriage with rotary bushings FTB	+	+



## Attachments Rear

	LR 626	LR 636
Counterweight, rear	•	•
Drawbar rear, rigid	+	+
Ripper, 3 shanks	+	+
Winch	<sup>1)</sup>	+



## Attachments Front

	LR 626	LR 636
Bolt-on cutting edges, reversible	+	+
Bolt-on cutting segments, reversible	+	+
Clamping cylinder guards, multi-purpose bucket	+	+
Lifting cylinder guards	+	+
Multi-purpose bucket	+	+
Standard bucket	+	+
Standard bucket HD	+	+
Teeth adapters bolt-on	+	+
Teeth adapters weld-on	+	+
Tilt cylinder guards	+	+
Trash rack for standard bucket	+	+
Trash rack multi-purpose bucket	+	+
Waste handling bucket	<sup>1)</sup>	+
Z-bar linkage	•	•

- = Standard
- + = Option
- = not available
- <sup>1)</sup> on demand at your dealer

Options and/or special attachments, supplied by vendors other than Liebherr, are only to be installed with the knowledge and approval of Liebherr in order to retain warranty.

# The Liebherr Group of Companies



## Wide Product Range

The Liebherr Group is one of the largest construction equipment manufacturers in the world. Liebherr's high-value products and services hold a high reputation in many industries. The wide range includes domestic appliances, aerospace and transportation systems, machine tools and maritime cranes.

## Exceptional Customer Benefit

Every product line provides a complete range of models in many different versions. With both their technical excellence and acknowledged quality, Liebherr products offer customers the highest benefits in practical applications.

## State-of-the-art Technology

Liebherr attributes great importance to the product areas of core technology and components, in order to achieve its consistent, top-quality products. Important modules and components are developed and manufactured in-house, for instance the entire drive and control technology for the construction equipment and mining trucks.

## Worldwide and Family-Owned

Hans Liebherr founded the Liebherr family company in 1949. Since that time, the enterprise has steadily grown to a group of more than 130 companies with over 41,000 employees located on all continents. The corporate headquarters of the Group is Liebherr-International AG in Bulle, Switzerland. The Liebherr family is the sole owner of the company.

[www.liebherr.us](http://www.liebherr.us)

## Liebherr-Werk Telfs GmbH

Hans Liebherr-Straße 35, A-6410 Telfs  
☎ +43 50809 6-100, Fax +43 50809 6-7772  
[www.liebherr.com](http://www.liebherr.com), E-Mail: [sales.lwt@liebherr.com](mailto:sales.lwt@liebherr.com)  
[www.facebook.com/LiebherrConstruction](https://www.facebook.com/LiebherrConstruction)